



dieter schätzle
präzisionswerkzeuge

HSS
Fräswerkzeuge

2023

Hinweis

Dieser Katalog ersetzt Ausgabe 2022.

Alle Preise verstehen sich rein netto, zzgl. der gesetzlichen Mehrwertsteuer.

Es gelten ausschließlich unsere allgemeinen Geschäftsbedingungen, welche Sie auf www.schaetzle-werkzeuge.de finden.

Die angegebenen Schnittwerte sind Richtwerte. Eine Anpassung in speziellen Einzelfällen ist zu empfehlen.

Für alle im Kataloge enthaltenen Werkzeuge wird zusätzlich ein Rohstoffsteuerzuschlag berechnet.
Wir behalten uns vor, den Zuschlag jederzeit anzupassen.

Abbildungen ähnlich, Druckfehler, Irrtümer und Änderungen vorbehalten.



Wir, die Firma Dieter Schätzle GmbH & Co. KG Präzisionswerkzeuge sind ein etablierter Hersteller von Fräs- und Bohrwerkzeugen. Unsere Kunden kommen aus verschiedenen Branchen wie der Medizintechnik, Automobilzulieferung und Luft- und Raumfahrt.

Als Spezialist für Sonderwerkzeuge entwickeln wir für jeden Kunden individuelle und ausgezeichnete Lösungen.

**Dieter Schätzle GmbH & Co. KG
Präzisionswerkzeuge**

Unter Haßlen 12
78532 Tuttlingen
T. +49 7462 / 9465 - 0
F. +49 7462 / 9465 - 50
E. auftrag@schaetzle-werkzeuge.de
W. www.schaetzle-werkzeuge.de
S. www.shop.schaetzle-werkzeuge.de/startseite/

Wir bieten Ihnen:

- kundenspezifische Produkte
- eine ausgezeichnete Qualität
- kurze Lieferzeiten
- individuelle Lösungen
- einen zuverlässigen Nachschleifservice
- eine Rundumbetreuung

Öffnungszeiten:

Montag - Freitag
07.30 Uhr - 12.00 Uhr
13.00 Uhr - 17.00 Uhr

Wir freuen uns auf Ihren Besuch.

Ihre Ansprechpartner in Sachen Sonderwerkzeuge und Nachschliff der Schätzle-Gruppe



S&B Werkzeugtechnologie GmbH









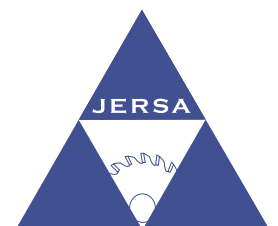





Unter Haßlen 12
78532 Tuttlingen
T. +49 7462 / 9465 - 0
F. +49 7462 / 9465 - 50
E. sb@schaetzle-werkzeuge.de
W. www.sbj-schaetzle.de



JERSA GmbH & Co. KG

Am Föhrenried 8
88255 Baidt
T. +49 7502 / 9435 - 0
F. +49 7502 / 9435 - 20
E. jersa@schaetzle-werkzeuge.de
W. www.sbj-schaetzle.de



HSS Fräswerkzeuge	Artikel		Beschreibung	geeignet für							Seite
	beschichtet	unbeschichtet		Stahl	Inox	Alu	GG(G)	Titan	Kupfer	Thermo- plaste	
	SBF0890		Winkelfräser Z8 - 12 beschichtet	••••	•••	•••	•••	••			6 - 7
	SBF0900		Winkelfräser Z10 - 12 beschichtet	••••	•••	•••	•••	••			8 - 9
	SBF0905		Schlitzfräser Z6 - 8 beschichtet	••••	•••	•••	•••	••			10 - 13
	SBF0910		T-Nutenfräser Z6 - 10 beschichtet	••••	•••		•••				14 - 15
	SBF0915		T-Nutenfräser Z6 - 8 beschichtet	••••	•••	•••	•••	••			16 - 17
	SBF0920		Viertelkreisfräser Z4 - 8 beschichtet	••••	•••		•••				18 - 19
	SBF0110		Schaftfräser Z3 - 6 beschichtet	••••	•••		•••	••			20 - 21
	SBF0200		Schaftfräser Z3 - 6 beschichtet	••••	•••		•••	••			22 - 23
	SBF0400		Schaftfräser Z3 beschichtet	••••	•••		•••	••			24 - 27
	SBF0410		Schaftfräser Z3 beschichtet	••••	•••		•••	•			28 - 29
	SBF0609		Schaftfräser Z4 - 5 beschichtet	••••	•••		•••	••			30 - 31
	SBF0610		Schaftfräser Z4 - 5 beschichtet	••••	•••		•••	•••			32 - 33
	SBF0619		Schaftfräser Z4 - 5 beschichtet	••••	•••		••	••			34 - 35
	SBF0640		Schaftfräser Z4 - 5 beschichtet	••••	•••		•••	••			36 - 37

HSS Fräswerkzeuge	Artikel		Beschreibung	geeignet für							Seite
	beschichtet	unbeschichtet		Stahl	Inox	Alu	GG(G)	Titan	Kupfer	Thermo- plaste	
	SBF0665		Schaftfräser Z4 beschichtet	••••	•••		•••	••			38 - 39
	SBF03400		Walzenstirnfräser beschichtet	••••	•		••				40 - 41
		SB03000	Walzenstirnfräser			••••			••••	••••	42 - 43
	SBF03200		Walzenstirnfräser beschichtet	••••	••		••				44 - 45
		SB05000	Scheibenfräser	••••	•	••	••				46 - 49
		SB03910	Schaftfräser			••••					50 - 51
		SB03930	Schaftfräser			••••					52 - 53
		SB08000	Zapfensenker	••••	•••	•••	•••	•			54
		SB07000	Zentrierbohrer	•••	•••		•••				55
Anhang											
			Härtevergleichstabelle								56
			Zerspanungsgruppen								57 - 58
			Abkürzungen, Formeln								59
			Zylinderschäfte für Hartmetallfräser								60

SBF0890

Werkstoff	D ₁ mm	z	V _c m/min	f mm/z	a _p mm	a _e mm	n u/min	V _f mm/min	
Stahl bis R_m 850 N/mm² ●●●									
	16	10	55	0,015	4	2,2	1094	164	
	20	10	55	0,018	5	2,4	875	158	
	25	10	55	0,02	6	2,6	700	140	
	32	10	55	0,025	8	3,0	547	137	
Stahl bis R_m 1100 N/mm² ●●●									
	16	10	45	0,015	4	2,2	895	134	
	20	10	45	0,018	5	2,4	716	129	
	25	10	45	0,02	6	2,6	573	115	
	32	10	45	0,025	8	3,0	448	112	
Stahl bis R_m 1300 N/mm² ●●●									
	16	10	30	0,015	4	2,2	597	90	
	20	10	30	0,018	5	2,4	477	86	
	25	10	30	0,02	6	2,6	382	76	
	32	10	30	0,025	8	3,0	298	75	
Nichtrostender Stahl ●●●									
	16	10	20	0,015	4	2,2	398	60	
	20	10	20	0,018	5	2,4	318	57	
	25	10	20	0,02	6	2,6	255	51	
	32	10	20	0,025	8	3,0	199	50	
Gusseisen ●●●									
	16	10	40	0,015	4	2,2	796	119	
	20	10	40	0,018	5	2,4	637	115	
	25	10	40	0,02	6	2,6	509	102	
	32	10	40	0,025	8	3,0	398	99	
Titan ●●									
	16	10	24	0,015	4	2,2	477	72	
	20	10	24	0,018	5	2,4	382	69	
	25	10	24	0,02	6	2,6	306	61	
	32	10	24	0,025	8	3,0	239	60	
Aluminium ●●●									
	16	10	80	0,02	4	2,2	1592	318	
	20	10	80	0,03	5	2,4	1273	382	
	25	10	80	0,04	6	2,6	1019	407	
	32	10	80	0,05	8	3,0	796	398	

Winkelfräser HSS

SBF0890
AlTiN - basierte Beschichtung

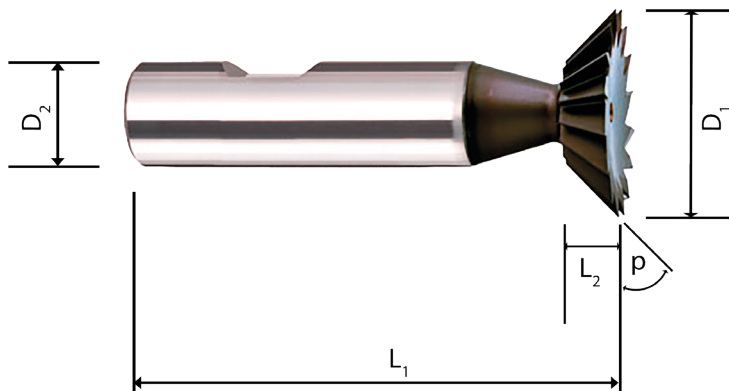

Technische Daten:	
Material:	HSS
Drallwinkel λ :	0°
Spanwinkel γ :	0°
Anzahl Schneiden:	8/10/12

Bestellnummer: SB(F) 0890 045160
 beschichtet Ø Code
 Seitenspannfläche: 0890

Werkstoff:

Stahl	Inox	Aluminium	Gusseisen	Titan
Stahl bis R_m 1100 N/mm ²	Nichtrostender Stahl	Nichteisenwerkstoffe		

Performance:

●●●● ●●● ●●● ●●● ●●

Ø Code	D_1 js16	D_2 h6		L_1	L_2	z	p			AlTiN basiert SBF0890
045120	12	10		54	2	8	45°			31,40 €
045160	16	12		60	4	10	45°			31,40 €
045200	20	12		63	5	10	45°			38,66 €
045250	25	12		67	6,3	10	45°			49,27 €
045320	32	16		71	8	10	45°			75,86 €
060160	16	12		60	6,3	10	60°			31,40 €
060200	20	12		63	8	10	60°			38,66 €
060250	25	12		67	10	10	60°			49,27 €
060320	32	16		71	12,5	12	60°			75,86 €
075160	16	12		60	8	10	75°			31,40 €
075250	25	12		67	10	12	75°			49,27 €

SBF0900

Werkstoff

D₁ **z** **V_c** **f** **a_p** **a_e** **n** **V_f**
mm **m/min** **mm/z** **mm** **mm** **u/min** **mm/min**

Stahl bis R_m 850 N/mm² ●●●●

16	10	55	0,015	4	2,2	1094	164	
20	10	55	0,018	5	2,4	875	158	
25	10	55	0,02	6	2,6	700	140	
32	10	55	0,025	8	3,0	547	137	

Stahl bis R_m 1100 N/mm² ●●●●

16	10	45	0,015	4	2,2	895	134	
20	10	45	0,018	5	2,4	716	129	
25	10	45	0,02	6	2,6	573	115	
32	10	45	0,025	8	3,0	448	112	

Stahl bis R_m 1300 N/mm² ●●●●

16	10	30	0,015	4	2,2	597	90	
20	10	30	0,018	5	2,4	477	86	
25	10	30	0,02	6	2,6	382	76	
32	10	30	0,025	8	3,0	298	75	

Nichtrostender Stahl ●●●

16	10	20	0,015	4	2,2	398	60	
20	10	20	0,018	5	2,4	318	57	
25	10	20	0,02	6	2,6	255	51	
32	10	20	0,025	8	3,0	199	50	

Gusseisen ●●●

16	10	40	0,015	4	2,2	796	119	
20	10	40	0,018	5	2,4	637	115	
25	10	40	0,02	6	2,6	509	102	
32	10	40	0,025	8	3,0	398	99	

Titan ●●

16	10	24	0,015	4	2,2	477	72	
20	10	24	0,018	5	2,4	382	69	
25	10	24	0,02	6	2,6	306	61	
32	10	24	0,025	8	3,0	239	60	

Aluminium ●●●

16	10	80	0,02	4	2,2	1592	318	
20	10	80	0,03	5	2,4	1273	382	
25	10	80	0,04	6	2,6	1019	407	
32	10	80	0,05	8	3,0	796	398	

Winkelfräser HSS

SBF0900
AlTiN - basierte Beschichtung

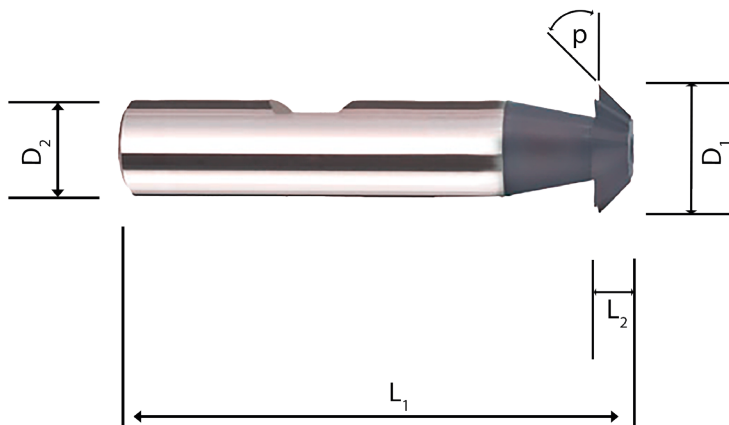

Technische Daten:	
Material:	HSS
Drallwinkel λ :	0°
Spanwinkel γ :	0°
Anzahl Schneiden:	10/12

Bestellnummer: SB(F) 0900 045160
 beschichtet
 Ø Code
 Seitenspannfläche: 0900

Werkstoff:

Stahl	Inox	Aluminium	Gusseisen	Titan
Stahl bis R _m 1100 N/mm ²	Nichtrostender Stahl	Nichteisenwerkstoffe		

Performance:

●●●● ●●● ●●● ●●● ●●

Ø Code	D ₁ js16	D ₂ h6	L ₁	L ₂	z	p		AlTiN basiert SBF0900
045160	16	12	60	4	10	45°		31,85 €
045200	20	12	63	5	10	45°		39,22 €
045250	25	12	67	6,3	10	45°		50,05 €
045320	32	16	71	8	10	45°		77,09 €
060160	16	12	60	6,3	10	60°		31,85 €
060200	20	12	63	8	10	60°		39,22 €
060250	25	12	67	10	10	60°		50,05 €
075160	16	12	60	8	10	75°		38,43 €
075250	25	12	67	10	12	75°		50,39 €

Werkstoff	D ₁ mm	z	V _c m/min	f mm/z	a _p mm	a _e mm	n u/min	V _f mm/min	
Stahl bis R_m 850 N/mm² ●●●●									
	4,5	6	55	0,003	1,0	1,0	3891	70	
	7,5	6	55	0,005	2,0	2,0	2334	70	
	10,5	6	55	0,01	2,9	2,5	1667	100	
	13,5	6	55	0,01	3,8	3,0	1297	78	
	16,5	6	55	0,025	5,0	4,0	1061	159	
	19,5	8	55	0,035	5,5	5,0	898	251	
Stahl bis R_m 1100 N/mm² ●●●●									
	4,5	6	45	0,003	1,0	1,0	3183	57	
	7,5	6	45	0,005	2,0	2,0	1910	57	
	10,5	6	45	0,01	2,9	2,5	1364	82	
	13,5	6	45	0,01	3,8	3,0	1061	64	
	16,5	6	45	0,025	5,0	4,0	868	130	
	19,5	8	45	0,035	5,5	5,0	735	206	
Stahl bis R_m 1300 N/mm² ●●●●									
	4,5	6	30	0,003	1,0	1,0	2122	38	
	7,5	6	30	0,005	2,0	2,0	1273	38	
	10,5	6	30	0,01	2,9	2,5	909	55	
	13,5	6	30	0,01	3,8	3,0	707	42	
	16,5	6	30	0,025	5,0	4,0	579	87	
	19,5	8	30	0,035	5,5	5,0	490	137	
Nichtrostender Stahl ●●●									
	4,5	6	20	0,003	1,0	1,0	1415	25	
	7,5	6	20	0,005	2,0	2,0	849	25	
	10,5	6	20	0,01	2,9	2,5	606	36	
	13,5	6	20	0,01	3,8	3,0	472	28	
	16,5	6	20	0,025	5,0	4,0	386	58	
	19,5	8	20	0,035	5,5	5,0	326	91	
Gusseisen ●●●									
	4,5	6	40	0,003	1,0	1,0	2830	51	
	7,5	6	40	0,005	2,0	2,0	1698	51	
	10,5	6	40	0,01	2,9	2,5	1213	73	
	13,5	6	40	0,01	3,8	3,0	943	57	
	16,5	6	40	0,025	5,0	4,0	772	116	
	19,5	8	40	0,035	5,5	5,0	653	183	
Titan ●●									
	4,5	6	24	0,003	1,0	1,0	1698	31	
	7,5	6	24	0,005	2,0	2,0	1019	31	
	10,5	6	24	0,01	2,9	2,5	728	44	
	13,5	6	24	0,01	3,8	3,0	566	34	
	16,5	6	24	0,025	5,0	4,0	463	69	
	19,5	8	24	0,035	5,5	5,0	392	110	
Aluminium ●●●									
	4,5	6	80	0,003	1,0	1,0	5659	170	
	7,5	6	80	0,005	2,0	2,0	3395	204	
	10,5	6	80	0,01	2,9	2,5	2425	291	
	13,5	6	80	0,01	3,8	3,0	1886	362	
	16,5	6	80	0,025	5,0	4,0	1543	417	
	19,5	8	80	0,035	5,5	5,0	1306	627	

Schlitzfräser HSS

SBF0905
AlTiN - basierte Beschichtung

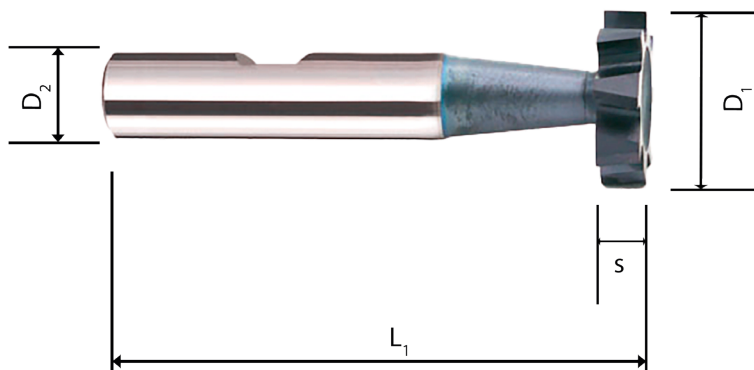

Technische Daten:	
Material:	HSS
Drallwinkel λ :	10°
Spanwinkel γ :	10°
Anzahl Schneiden:	6/8/10

Bestellnummer: SB(F) 0905 045010
 beschichtet
 Ø Code
 Seitenspannfläche: 0905

Werkstoff:

Stahl	Inox	Aluminium	Gusseisen	Titan
Stahl bis R_m 1100 N/mm ²	Nichtrostender Stahl	Nichteisenwerkstoffe		

Performance:

●●●● ●●● ●●● ●●● ●●

Ø Code	D_1 d12	D_2 h6	s e8	L_1	Z	AlTiN basiert SBF0905
045010	4,5	6	1	50	6	24,92 €
075015	7,5	6	1,5	50	6	25,81 €
075020	7,5	6	2	50	6	25,81 €
105020	10,5	6	2	50	6	28,15 €
105025	10,5	6	2,5	50	6	28,15 €
105030	10,5	6	3	50	6	28,15 €
135020	13,5	10	2	56	6	28,38 €
135030	13,5	10	3	56	6	28,38 €
135040	13,5	10	4	56	6	28,38 €
165030	16,5	10	3	56	6	28,72 €
165040	16,5	10	4	56	6	28,72 €
165050	16,5	10	5	56	6	28,72 €
195030	19,5	10	3	63	8	34,75 €
195040	19,5	10	4	63	8	34,75 €
195050	19,5	10	5	63	8	34,75 €
195060	19,5	10	6	63	8	34,75 €
225040	22,5	10	4	63	8	39,55 €
225050	22,5	10	5	63	8	39,55 €
225060	22,5	10	6	63	8	39,55 €
225080	22,5	10	8	63	8	39,55 €
255050	25,5	10	5	63	10	45,92 €

Werkstoff	D_1 mm	z	V_c m/min	f mm/z	a_p mm	a_e mm	n u/min	V_f mm/min	
Stahl bis R_m 850 N/mm² ●●●									
	19,5	8	55	0,035	5,5	5	898	251	
	22,5	8	55	0,04	6,6	6	778	249	
	25,5	10	55	0,045	7,5	6	687	309	
	28,5	10	55	0,05	8,2	8	614	307	
	32,5	10	55	0,06	9,8	10	539	323	
	45,5	12	55	0,08	12	10	385	369	
Stahl bis R_m 1100 N/mm² ●●●									
	19,5	8	45	0,035	5,5	5	735	206	
	22,5	8	45	0,04	6,6	6	637	204	
	25,5	10	45	0,045	7,5	6	562	253	
	28,5	10	45	0,05	8,2	8	503	251	
	32,5	10	45	0,06	9,8	10	441	264	
	45,5	12	45	0,08	12	10	315	302	
Stahl bis R_m 1300 N/mm² ●●●									
	19,5	8	30	0,035	5,5	5	490	137	
	22,5	8	30	0,04	6,6	6	424	136	
	25,5	10	30	0,045	7,5	6	374	169	
	28,5	10	30	0,05	8,2	8	335	168	
	32,5	10	30	0,06	9,8	10	294	176	
	45,5	12	30	0,08	12	10	210	201	
Nichtrostender Stahl ●●●									
	19,5	8	20	0,035	5,5	5	326	91	
	22,5	8	20	0,04	6,6	6	283	91	
	25,5	10	20	0,045	7,5	6	250	112	
	28,5	10	20	0,05	8,2	8	223	112	
	32,5	10	20	0,06	9,8	10	196	118	
	45,5	12	20	0,08	12	10	140	134	
Gusseisen ●●●									
	19,5	8	40	0,035	5,5	5	653	183	
	22,5	8	40	0,04	6,6	6	566	181	
	25,5	10	40	0,045	7,5	6	499	225	
	28,5	10	40	0,05	8,2	8	447	223	
	32,5	10	40	0,06	9,8	10	392	235	
	45,5	12	40	0,08	12	10	280	269	
Titan ●●									
	19,5	8	24	0,035	5,5	5	392	110	
	22,5	8	24	0,04	6,6	6	340	109	
	25,5	10	24	0,045	7,5	6	300	135	
	28,5	10	24	0,05	8,2	8	268	134	
	32,5	10	24	0,06	9,8	10	235	141	
	45,5	12	24	0,08	12	10	168	161	
Aluminium ●●●									
	19,5	8	80	0,035	5,5	5	1306	627	
	22,5	8	80	0,04	6,6	6	1132	634	
	25,5	10	80	0,045	7,5	6	999	799	
	28,5	10	80	0,05	8,2	8	894	804	
	32,5	10	80	0,06	9,8	10	784	784	
	45,5	12	80	0,08	12	10	560	806	

Schlitzfräser HSS

SBF0905
AlTiN - basierte Beschichtung

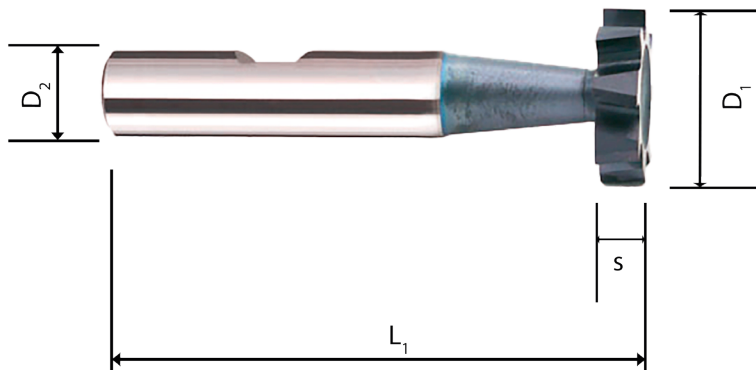

Technische Daten:	
Material:	HSS
Drallwinkel λ :	10°
Spanwinkel γ :	10°
Anzahl Schneiden:	10/12

Bestellnummer: SB(F) 0905 195060
 beschichtet
 Ø Code
 Seitenspannfläche: 0905

Werkstoff:

Stahl	Inox	Aluminium	Gusseisen	Titan
Stahl bis R_m 1100 N/mm ²	Nichtrostender Stahl	Nichteisenwerkstoffe		

Performance:

●●●● ●●● ●●● ●●● ●●

Ø Code	D_1 d12	D_2 h6	s e8	L_1	Z	AlTiN basiert SBF0905
255060	25,5	10	6	63	10	45,92 €
285060	28,5	10	6	63	10	60,22 €
285080	28,5	10	8	63	10	60,22 €
285100	28,5	12	10	71	10	60,22 €
325060	32,5	12	6	71	10	68,82 €
325070	32,5	12	7	71	10	68,82 €
325080	32,5	12	8	71	10	68,82 €
325100	32,5	12	10	71	12	68,82 €
455100	45,5	12	10	71	12	119,66 €

Werkstoff	D_1 mm	z	V_c m/min	f mm/z	a_p mm	a_e mm	n u/min	V_f mm/min	
Stahl bis R_m 850 N/mm² ●●●●									
	11	6	55	0,01	4	1,1	1592	95	
	12,5	6	55	0,01	6	1,3	1401	84	
	16	6	55	0,025	8	1,6	1094	164	
	18	6	55	0,025	8	1,8	973	146	
	21	6	55	0,04	9	2,1	834	200	
	25	8	55	0,045	11	2,5	700	252	
	32	8	55	0,06	14	3,2	547	263	
	40	10	55	0,07	18	4	438	306	
	50	10	55	0,09	22	5	350	315	
Stahl bis R_m 1100 N/mm² ●●●●									
	11	6	45	0,01	4	1,1	1302	78	
	12,5	6	45	0,01	6	1,3	1146	68	
	16	6	45	0,025	8	1,6	895	134	
	18	6	45	0,025	8	1,8	796	119	
	21	6	45	0,04	9	2,1	682	164	
	25	8	45	0,045	11	2,5	573	206	
	32	8	45	0,06	14	3,2	448	215	
	40	10	45	0,07	18	4	358	251	
	50	10	45	0,09	22	5	286	258	
Stahl bis R_m 1300 N/mm² ●●●●									
	11	6	30	0,01	4	1,1	868	52	
	12,5	6	30	0,01	6	1,3	764	46	
	16	6	30	0,025	8	1,6	597	90	
	18	6	30	0,025	8	1,8	531	80	
	21	6	30	0,04	9	2,1	455	109	
	25	8	30	0,045	11	2,5	382	138	
	32	8	30	0,06	14	3,2	298	143	
	40	10	30	0,07	18	4	239	167	
	50	10	30	0,09	22	5	191	172	
Nichtrostender Stahl ●●●									
	11	6	20	0,01	4	1,1	579	35	
	12,5	6	20	0,01	6	1,3	509	31	
	16	6	20	0,025	8	1,6	398	60	
	18	6	20	0,025	8	1,8	354	53	
	21	6	20	0,04	9	2,1	303	73	
	25	8	20	0,045	11	2,5	255	92	
	32	8	20	0,06	14	3,2	199	95	
	40	10	20	0,07	18	4	159	111	
	50	10	20	0,09	22	5	127	115	
Gusseisen ●●●									
	11	6	40	0,01	4	1,1	1158	69	
	12,5	6	40	0,01	6	1,3	1019	61	
	16	6	40	0,025	8	1,6	796	119	
	18	6	40	0,025	8	1,8	707	106	
	21	6	40	0,04	9	2,1	606	146	
	25	8	40	0,045	11	2,5	509	183	
	32	8	40	0,06	14	3,2	398	191	
	40	10	40	0,07	18	4	318	223	
	50	10	40	0,09	22	5	255	229	

T-Nutenfräser HSS

SBF0910
AlTiN - basierte Beschichtung

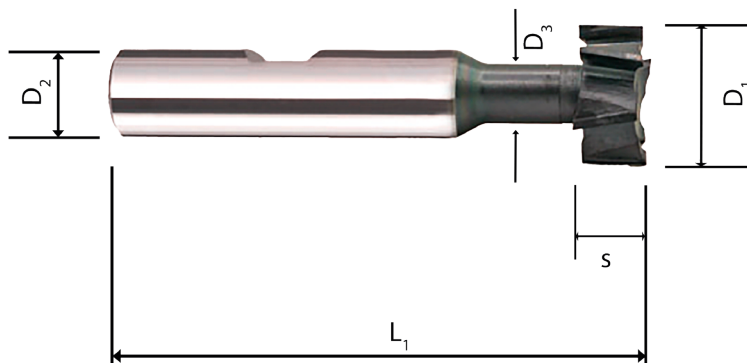

Technische Daten:	
Material:	HSS
Drallwinkel λ :	10°
Spanwinkel γ :	20°
Anzahl Schneiden:	6/8/10

Bestellnummer: SB(F) 0910 110
 beschichtet
 Ø Code
 Seitenspannfläche: 0910

Werkstoff:

Stahl	Inox	Gusseisen
Stahl bis R_m 1100 N/mm ²	Nichtrostender Stahl	

Performance:

●●●●

●●●

●●●

Ø Code	D_1 d11	D_2 h6	s d11	D_3	L_1	z				AlTiN basiert SBF0910
110	11	10	4	4	53,5	6				41,45 €
125	12,5	10	6	5	57	6				44,24 €
160	16	10	8	7	62	6				47,71 €
180	18	12	8	8	70	6				53,18 €
210	21	12	9	10	74	6				59,44 €
250	25	16	11	12	82	8				70,38 €
320	32	16	14	15	90	8				96,97 €
400	40	25	18	19	108	10				168,92 €
500	50	32	22	25	124	10				214,28 €

Werkstoff	D_1 mm	z	V_c m/min	f mm/z	a_p mm	a_e mm	n u/min	V_f mm/min	
Stahl bis R_m 850 N/mm² ●●●●									
	16	6	55	0,02	8	16	1094	131	
	18	6	55	0,02	8	18	973	117	
	21	6	55	0,03	9	21	834	150	
	25	8	55	0,04	11	25	700	224	
	32	8	55	0,05	14	32	547	219	
	40	8	55	0,06	18	40	438	210	
Stahl bis R_m 1100 N/mm² ●●●●									
	16	6	45	0,02	8	16	895	107	
	18	6	45	0,02	8	18	796	95	
	21	6	45	0,03	9	21	682	123	
	25	8	45	0,04	11	25	573	183	
	32	8	45	0,05	14	32	448	179	
	40	8	45	0,06	18	40	358	172	
Stahl bis R_m 1300 N/mm² ●●●●									
	16	6	30	0,02	8	16	597	72	
	18	6	30	0,02	8	18	531	64	
	21	6	30	0,03	9	21	455	82	
	25	8	30	0,04	11	25	382	122	
	32	8	30	0,05	14	32	298	119	
	40	8	30	0,06	18	40	239	115	
Nichtrostender Stahl ●●●									
	16	6	20	0,02	8	16	398	48	
	18	6	20	0,02	8	18	354	42	
	21	6	20	0,03	9	21	303	55	
	25	8	20	0,04	11	25	255	81	
	32	8	20	0,05	14	32	199	80	
	40	8	20	0,06	18	40	159	76	
Gusseisen ●●●									
	16	6	40	0,02	8	16	796	95	
	18	6	40	0,02	8	18	707	85	
	21	6	40	0,03	9	21	606	109	
	25	8	40	0,04	11	25	509	163	
	32	8	40	0,05	14	32	398	159	
	40	8	40	0,06	18	40	318	153	
Titan ●●									
	16	6	24	0,02	8	16	477	57	
	18	6	24	0,02	8	18	424	51	
	21	6	24	0,03	9	21	364	65	
	25	8	24	0,04	11	25	306	98	
	32	8	24	0,05	14	32	239	95	
	40	8	24	0,06	18	40	191	92	
Aluminium ●●●									
	16	6	80	0,02	8	16	1592	382	
	18	6	80	0,02	8	18	1415	424	
	21	6	80	0,03	9	21	1213	437	
	25	8	80	0,04	11	25	1019	652	
	32	8	80	0,05	14	32	796	573	
	40	8	80	0,06	18	40	637	611	

T-Nutenfräser HSS

SBF0915
AlTiN - basierte Beschichtung

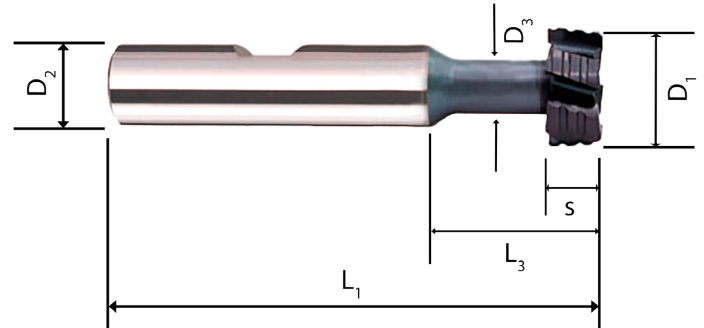

Technische Daten:	
Material:	HSS
Drallwinkel λ :	10°
Spanwinkel γ :	20°
Profil:	NR-F
Anzahl Schneiden:	6/8

Bestellnummer: SB(F) 0915 160
 beschichtet
 Ø Code
 Seitenspannfläche: 0915

Werkstoff:

Stahl	Inox	Aluminium	Gusseisen	Titan
Stahl bis R_m 1100 N/mm ²	Nichtrostender Stahl	Nichteisenwerkstoffe		

Performance:

●●●● ●●● ●●● ●●● ●●

Ø Code	D_1 d11	D_2 h6	D_3	L_1	L_3	S d11	Z			AlTiN basiert SBF0915
160	16	10	7	62	22	8	6			53,97 €
180	18	12	8	70	25	8	6			59,44 €
210	21	12	10	74	29	9	6			68,04 €
250	25	16	12	82	34	11	8			79,77 €
320	32	16	15	90	42	14	8			104,79 €
400	40	25	19	108	52	18	10			161,10 €

Werkstoff	D ₁ mm	z	V _c m/min	f mm/z	a _p mm	a _e mm	n u/min	V _f mm/min	
Stahl bis R_m 850 N/mm² ●●●●									
	8	4	55	0,006	1	1	2188	53	
	12	4	55	0,01	3	3	1459	58	
	16	4	55	0,025	5	5	1094	109	
	20	4	55	0,03	6	6	875	105	
	24	4	55	0,04	8	8	729	117	
	34	4	55	0,05	12	12	515	103	
	56	6	55	0,06	20	20	313	113	

Stahl bis R_m 1100 N/mm² ●●●●									
	8	4	45	0,006	1	1	1791	43	
	12	4	45	0,01	3	3	1194	48	
	16	4	45	0,025	5	5	895	90	
	20	4	45	0,03	6	6	716	86	
	24	4	45	0,04	8	8	597	95	
	34	4	45	0,05	12	12	421	84	
	56	6	45	0,06	20	20	256	92	

Stahl bis R_m 1300 N/mm² ●●●●									
	8	4	30	0,006	1	1	1194	29	
	12	4	30	0,01	3	3	796	32	
	16	4	30	0,025	5	5	597	60	
	20	4	30	0,03	6	6	477	57	
	24	4	30	0,04	8	8	398	64	
	34	4	30	0,05	12	12	281	56	
	56	6	30	0,06	20	20	171	61	

Nichtrostender Stahl ●●●									
	8	4	20	0,006	1	1	796	19	
	12	4	20	0,01	3	3	531	21	
	16	4	20	0,025	5	5	398	40	
	20	4	20	0,03	6	6	318	38	
	24	4	20	0,04	8	8	265	42	
	34	4	20	0,05	12	12	187	37	
	56	6	20	0,06	20	20	114	41	
	32	5	21	0,050	10	10	210	50	
	38	6	21	0,060	12	12	175	65	

Gusseisen ●●●									
	8	4	40	0,006	1	1	1592	38	
	12	4	40	0,01	3	3	1061	42	
	16	4	40	0,025	5	5	796	80	
	20	4	40	0,03	6	6	637	76	
	24	4	40	0,04	8	8	531	85	
	34	4	40	0,05	12	12	374	75	
	56	6	40	0,06	20	20	227	82	

Viertelkreisfräser HSS

SBF0920
AlTiN - basierte Beschichtung

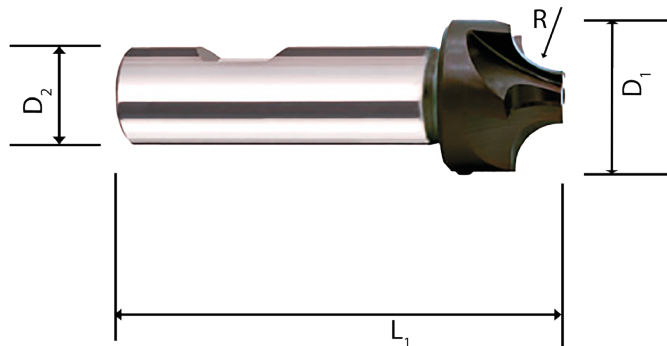

Technische Daten:	
Material:	HSS
Drallwinkel λ :	10°
Spanwinkel γ :	0°
Anzahl Schneiden	4/6

Bestellnummer: SB(F) 0920 010
 beschichtet
 Ø Code
 Seitenspannfläche: 0920

Werkstoff:

Stahl	Inox	Gusseisen
Stahl bis R _m 1100 N/mm ²	Nichtrostender Stahl	

Performance:

●●●● ●●● ●●●

Ø Code	R H11	D ₁ js15	D ₂ h6	L ₁	z					AlTiN basiert SBF0920
010	1	8	10	60	4					36,31 €
015	1,5	9	10	60	4					33,07 €
020	2	10	10	60	4					34,63 €
025	2,5	11	10	60	4					35,64 €
030	3	12	12	60	4					37,54 €
040	4	14	12	60	4					39,33 €
050	5	16	12	60	4					42,23 €
060	6	20	16	67	4					48,49 €
070	7	22	16	71	4					63,35 €
080	8	24	16	71	4					67,03 €
100	10	28	25	85	4					83,68 €
120	12	34	25	90	4					90,72 €
150	15	46	25	100	6					150,94 €
200	20	56	32	112	6					254,17 €

Werkstoff	D_1 mm	z	V_c m/min	f mm/z	a_p mm	a_e mm	n u/min	V_f mm/min	
Stahl bis R_m 850 N/mm² ●●●●									
	3	4	55	0,006	3	0,3	5836	140	
	6	4	55	0,015	6	0,6	2918	175	
	8	4	55	0,021	8	0,8	2188	184	
	10	4	55	0,028	10	1	1751	196	
	12	4	55	0,034	12	1,2	1459	198	
	16	4	55	0,044	16	1,6	1094	193	
	18	4	55	0,051	18	1,8	973	198	
	20	4	55	0,057	20	2	875	200	
	25	5	55	0,071	25	2,5	700	249	
	36	6	55	0,1	36	3,6	486	292	
Stahl bis R_m 1100 N/mm² ●●●●									
	3	4	40	0,006	3	0,3	4244	102	
	6	4	40	0,015	6	0,6	2122	127	
	8	4	40	0,021	8	0,8	1592	134	
	10	4	40	0,028	10	1	1273	143	
	12	4	40	0,034	12	1,2	1061	144	
	16	4	40	0,044	16	1,6	796	140	
	18	4	40	0,051	18	1,8	707	144	
	20	4	40	0,057	20	2	637	145	
	25	5	40	0,071	25	2,5	509	181	
	36	6	40	0,1	36	3,6	354	212	
Gusseisen <240HB ●●●									
	3	4	52	0,006	3	0,3	5518	132	
	6	4	52	0,015	6	0,6	2759	166	
	8	4	52	0,021	8	0,8	2069	174	
	10	4	52	0,028	10	1	1655	185	
	12	4	52	0,034	12	1,2	1379	188	
	16	4	52	0,044	16	1,6	1035	182	
	18	4	52	0,051	18	1,8	920	188	
	20	4	52	0,057	20	2	828	189	
	25	5	52	0,071	25	2,5	662	235	
	36	6	52	0,1	36	3,6	460	276	
CrNi-Legierungen <1500 N/mm² ●●●●									
	3	4	17	0,006	3	0,3	1804	29	
	6	4	17	0,015	6	0,6	902	40	
	8	4	17	0,021	8	0,8	676	41	
	10	4	17	0,028	10	1	541	43	
	12	4	17	0,034	12	1,2	451	43	
	16	4	17	0,044	16	1,6	338	42	
	18	4	17	0,051	18	1,8	301	43	
	20	4	17	0,057	20	2	271	43	
	25	5	17	0,071	25	2,5	216	65	
	36	6	17	0,1	36	3,6	150	72	

Schaftfräser HSS-E

SBF0110
AlTiN - basierte Beschichtung

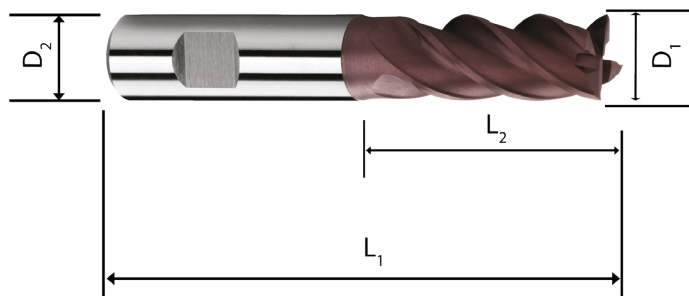

Technische Daten:	
Material:	HSS-Co8
Drallwinkel λ :	40°
Spanwinkel γ :	12°
Anzahl Schneiden:	3/4/5/6

Bestellnummer: SB(F) 0110 020
 beschichtet
 Ø Code
 Seitenspannfläche: 0110

Werkstoff:

Stahl	Inox	Gusseisen	Titan
Stahl bis R_m 1100 N/mm ²	Nichtrostender Stahl		CrNi
●●●●	●●●	●●●	●●

Performance:

Ø Code	D_1 k10	D_2 h6	L_1	L_2	z					AlTiN basiert SBF0110
020	2	6	51	7	3					10,73 €
025	2,5	6	52	8	3					10,73 €
030	3	6	52	8	4					10,73 €
035	3,5	6	54	10	4					10,73 €
040	4	6	55	11	4					10,73 €
045	4,5	6	55	11	4					10,73 €
050	5	6	57	13	4					10,73 €
055	5,5	6	57	13	4					10,73 €
060	6	6	57	13	4					10,73 €
080	8	10	69	19	4					15,01 €
100	10	10	72	22	4					16,12 €
110	11	12	79	22	4					18,27 €
120	12	12	83	26	4					18,27 €
140	14	12	83	26	4					25,82 €
150	15	12	83	26	4					25,82 €
160	16	16	92	32	4					25,82 €
180	18	16	92	32	4					32,89 €
200	20	20	104	38	4					32,89 €
220	22	20	104	38	4					54,81 €
250	25	25	121	45	5					54,81 €
360	36	32	133	53	6					176,34 €

SBF0200

Werkstoff	D ₁ mm	z	V _c m/min	f mm/z	a _p mm	a _e mm	n u/min	V _f mm/min	
Stahl bis R_m 850 N/mm² ●●●●									
	3	4	28	0,005	3	0,3	2971	61	
	6	4	28	0,013	6	0,6	1485	76	
	8	4	28	0,018	8	0,8	1114	80	
	10	4	28	0,024	10	1	891	85	
	12	4	28	0,029	12	1,2	743	86	
	16	4	28	0,037	16	1,6	557	83	
	18	4	28	0,043	18	1,8	495	86	
	20	4	28	0,048	20	2	446	86	
	25	5	28	0,060	25	2,5	357	108	
	36	6	28	0,085	36	3,6	248	126	
Stahl bis R_m 1100 N/mm² ●●●●									
	3	4	20	0,005	3	0,3	2122	43	
	6	4	20	0,013	6	0,6	1061	54	
	8	4	20	0,018	8	0,8	796	57	
	10	4	20	0,024	10	1	637	61	
	12	4	20	0,029	12	1,2	531	61	
	16	4	20	0,037	16	1,6	398	60	
	18	4	20	0,043	18	1,8	354	61	
	20	4	20	0,048	20	2	318	62	
	25	5	20	0,060	25	2,5	255	77	
	36	6	20	0,085	36	3,6	177	90	
Gusseisen <240HB ●●●									
	3	4	26	0,005	3	0,3	2759	60	
	6	4	26	0,014	6	0,6	1379	74	
	8	4	26	0,019	8	0,8	1035	78	
	10	4	26	0,025	10	1	828	83	
	12	4	26	0,031	12	1,2	690	84	
	16	4	26	0,040	16	1,6	517	82	
	18	4	26	0,046	18	1,8	460	84	
	20	4	26	0,051	20	2	414	85	
	25	5	26	0,064	25	2,5	331	106	
	36	6	26	0,090	36	3,6	230	124	
CrNi-Legierungen <1500 N/mm² ●●●●									
	3	4	8	0,004	3	0,3	849	12	
	6	4	8	0,010	6	0,6	424	17	
	8	4	8	0,014	8	0,8	318	17	
	10	4	8	0,018	10	1	255	18	
	12	4	8	0,022	12	1,2	212	18	
	16	4	8	0,028	16	1,6	159	18	
	18	4	8	0,032	18	1,8	141	18	
	20	4	8	0,036	20	2	127	18	
	25	5	8	0,054	25	2,5	102	28	
	36	6	8	0,072	36	3,6	71	31	

Schaftfräser HSS-E

SBF0200
AlTiN - basierte Beschichtung

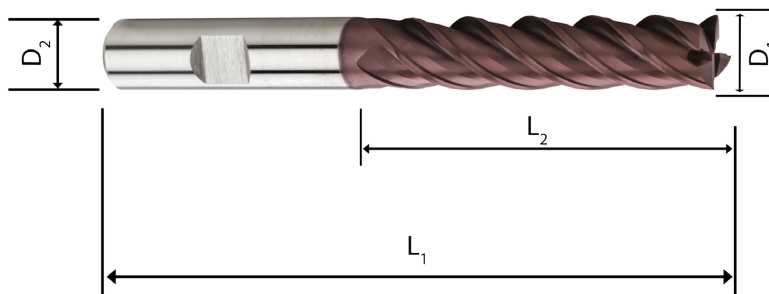

Technische Daten:	
Material:	HSS-Co8
Drallwinkel λ :	40°
Spanwinkel γ :	12°
Anzahl Schneiden:	3/4/5/6

Bestellnummer: SB(F) 0200 020

beschichtet | Ø Code

Seitenspannfläche: 0200

Werkstoff:

Stahl	Inox	Gusseisen	Titan
Stahl bis R_m 1100 N/mm ²	Nichtrostender Stahl		CrNi
●●●●	●●●	●●●	●●

Performance:

Ø Code	D ₁ k10	D ₂ h6	L ₁	L ₂	z					AlTiN basiert SBF0200
020	2	6	54	10	3					14,14 €
030	3	6	56	12	4					14,14 €
050	5	6	68	24	4					14,14 €
060	6	6	68	24	4					14,14 €
080	8	10	88	38	4					19,86 €
100	10	10	95	45	4					21,21 €
120	12	12	110	53	4					24,07 €
140	14	12	110	53	4					33,99 €
180	18	16	123	63	4					43,29 €
200	20	20	141	75	4					43,29 €
220	22	20	141	75	4					73,08 €
300	30	25	166	90	5					129,47 €
320	32	32	186	106	6					129,47 €
400	40	32	217	125	6					232,74 €

SBFO400

Werkstoff	D ₁ mm	z	V _c m/min	f mm/z	a _p mm	a _e mm	n u/min	V _f mm/min	
Stahl bis R_m 850 N/mm² ●●●●									
	1	3	58	0,004	1	0,1	18463	222	
	3	3	58	0,010	3	0,3	6154	185	
	4	3	58	0,013	4	0,4	4616	180	
	5	3	58	0,017	5	0,5	3693	183	
	6	3	58	0,020	6	0,6	3077	185	
Stahl bis R_m 1100 N/mm² ●●●●									
	1	3	36	0,004	1	0,1	11459	138	
	3	3	36	0,008	3	0,3	3820	92	
	4	3	36	0,011	4	0,4	2865	95	
	5	3	36	0,014	5	0,5	2292	96	
	6	3	36	0,016	6	0,6	1910	92	
Stahl bis R_m 1100 N/mm² ●●●●									
	1	3	30	0,004	1	0,1	9550	115	
	3	3	30	0,008	3	0,3	3183	76	
	4	3	30	0,011	4	0,4	2387	79	
	5	3	30	0,014	5	0,5	1910	80	
	6	3	30	0,016	6	0,6	1592	76	
Nichtrostender Stahl ●●●									
	1	3	22	0,005	1	0,1	7003	105	
	3	3	22	0,010	3	0,3	2334	69	
	4	3	22	0,012	4	0,4	1751	63	
	5	3	22	0,015	5	0,5	1401	63	
	6	3	22	0,018	6	0,6	1167	63	
Gusseisen < 240HB ●●									
	1	3	52	0,005	1	0,1	16553	248	
	3	3	52	0,011	3	0,3	5518	182	
	4	3	52	0,014	4	0,4	4138	174	
	5	3	52	0,018	5	0,5	3311	179	
	6	3	52	0,022	6	0,6	2759	182	
	1	3	38	0,004	1	0,1	12096	145	
	3	3	38	0,010	3	0,3	4032	121	
	4	3	38	0,013	4	0,4	3024	118	
	5	3	38	0,016	5	0,5	2419	116	
	6	3	38	0,020	6	0,6	2016	121	

Schaftfräser HSS-E

SBF0400
AlTiN - basierte Beschichtung

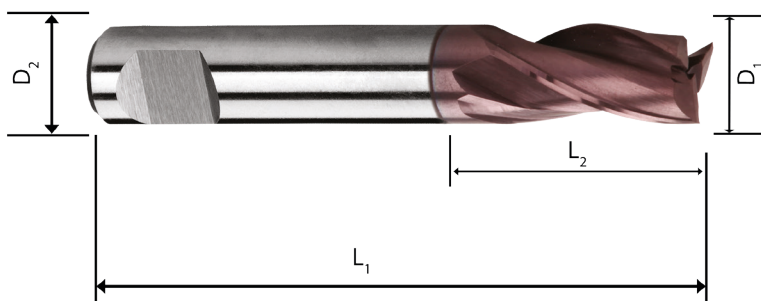

Technische Daten:	
Material:	HSS-Co8
Drallwinkel λ :	30°
Spanwinkel γ :	12°
Anzahl Schneiden:	3

Bestellnummer: SB(F) 0400 010
 beschichtet
 Ø Code
 Seitenspannfläche: 0400

Werkstoff:

Stahl	Inox	Gusseisen	Titan
Stahl bis R_m 1100 N/mm ²	Nichtrostender Stahl		CrNi
●●●●	●●●	●●	●

Performance:

Ø Code	D_1 k10	D_2 h6	L_1	L_2	z					AlTiN basiert SBF0400
010	1	6	34	3	3					8,10 €
015	1,5	6	34	3	3					8,10 €
018	1,8	6	34	3	3					8,10 €
020	2	6	35	4	3					8,10 €
023	2,3	6	35	4	3					8,10 €
025	2,5	6	36	5	3					8,10 €
028	2,8	6	36	5	3					8,10 €
030	3	6	36	5	3					8,10 €
033	3,3	6	37	6	3					8,10 €
035	3,5	6	37	6	3					8,10 €
040	4	6	38	7	3					8,10 €
043	4,3	6	38	7	3					8,10 €
045	4,5	6	38	7	3					8,10 €
048	4,8	6	39	8	3					8,10 €
050	5	6	39	8	3					8,10 €
053	5,3	6	39	8	3					8,10 €
055	5,5	6	39	8	3					8,10 €
0575	5,75	6	39	8	3					8,10 €
060	6	6	39	8	3					8,10 €

SBFO400

Werkstoff	D ₁ mm	z	V _c m/min	f mm/z	a _p mm	a _e mm	n u/min	V _f mm/min	
Stahl bis R_m 850 N/mm² ●●●●									
	6,5	3	58	0,020	6	0,6	3077	185	
	8	3	58	0,026	8	0,8	2308	180	
	10	3	58	0,033	10	1	1846	183	
	12	3	58	0,040	12	1,2	1539	185	
Stahl bis R_m 1100 N/mm² ●●●●									
	6,5	3	36	0,016	6	0,6	1910	92	
	8	3	36	0,022	8	0,8	1432	95	
	10	3	36	0,030	10	1	1146	103	
	12	3	36	0,037	12	1,2	955	106	
Stahl bis R_m 1100 N/mm² ●●●●									
	6,5	3	30	0,016	6	0,6	1592	76	
	8	3	30	0,022	8	0,8	1194	79	
	10	3	30	0,030	10	1	955	86	
	12	3	30	0,037	12	1,2	796	88	
Nichtrostender Stahl ●●●									
	6,5	3	22	0,018	6	0,6	1167	63	
	8	3	22	0,024	8	0,8	875	63	
	10	3	22	0,030	10	1	700	63	
	12	3	22	0,037	12	1,2	584	63	
Gusseisen < 240HB ●●									
	6,5	3	52	0,022	6	0,6	2759	182	
	8	3	52	0,029	8	0,8	2069	180	
	10	3	52	0,036	10	1	1655	179	
	12	3	52	0,043	12	1,2	1379	178	
	6,5	3	38	0,020	6	0,6	2016	121	
	8	3	38	0,026	8	0,8	1512	118	
	10	3	38	0,033	10	1	1210	120	
	12	3	38	0,038	12	1,2	1008	115	

Schaftfräser HSS-E

SBF0400
AlTiN - basierte Beschichtung

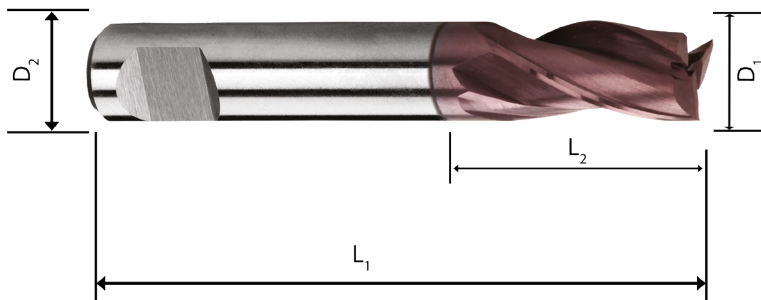

Technische Daten:	
Material:	HSS-Co8
Drallwinkel λ :	30°
Spanwinkel γ :	12°
Anzahl Schneiden:	3

Bestellnummer: SB(F) 0400 010
 beschichtet
 Ø Code
 Seitenspannfläche: 0400

Werkstoff:

Stahl	Inox	Gusseisen	Titan
Stahl bis R_m 1100 N/mm ²	Nichtrostender Stahl		CrNi
●●●●	●●●	●●	●

Performance:

Ø Code	D ₁ k10	D ₂ h6	L ₁	L ₂	Z					AlTiN basiert SBF0400
065	6,5	8	42	10	3					11,36 €
070	7	8	42	10	3					11,36 €
075	7,5	8	42	10	3					11,36 €
080	8	8	43	11	3					11,36 €
085	8,5	10	48	11	3					12,15 €
090	9	10	48	11	3					12,15 €
100	10	10	50	13	3					12,15 €
120	12	12	73	16	3					13,82 €

Werkstoff	D_1 mm	z	V_c m/min	f mm/z	a_p mm	a_e mm	n u/min	V_f mm/min	
Stahl bis R_m 850 N/mm² ●●●●									
	2	3	58	0,004	2	0,2	9231	111	
	3	3	58	0,010	3	0,3	6154	185	
	4	3	58	0,013	4	0,4	4616	180	
	5	3	58	0,017	5	0,5	3693	183	
	6	3	58	0,020	6	0,6	3077	185	
Stahl bis R_m 1100 N/mm² ●●●●									
	2	3	36	0,004	2	0,2	5730	69	
	3	3	36	0,008	3	0,3	3820	92	
	4	3	36	0,011	4	0,4	2865	95	
	5	3	36	0,014	5	0,5	2292	96	
	6	3	36	0,016	6	0,6	1910	92	
Nichtrostender Stahl ●●●									
	2	3	22	0,005	2	0,2	3502	53	
	3	3	22	0,010	3	0,3	2334	69	
	4	3	22	0,012	4	0,4	1751	63	
	5	3	22	0,015	5	0,5	1401	63	
	6	3	22	0,018	6	0,6	1167	63	
Gusseisen <240 HB ●●									
	2	3	52	0,005	2	0,2	8276	124	
	3	3	52	0,011	3	0,3	5518	182	
	4	3	52	0,014	4	0,4	4138	174	
	5	3	52	0,018	5	0,5	3311	179	
	6	3	52	0,022	6	0,6	2759	182	
CrNi-Legierungen <1500 N/mm² ●									
	2	3	32	0,004	2	0,2	5093	61	
	3	3	32	0,008	3	0,3	3395	81	
	4	3	32	0,010	4	0,4	2547	76	
	5	3	32	0,012	5	0,5	2037	73	
	6	3	32	0,015	6	0,6	1698	76	
Titan <1200 N/mm² ●									
	2	3	28	0,004	2	0,2	4456	53	
	3	3	28	0,008	3	0,3	2971	71	
	4	3	28	0,010	4	0,4	2228	67	
	5	3	28	0,012	5	0,5	1783	64	
	6	3	28	0,015	6	0,6	1485	67	

Schaftfräser HSS-E

SBF0410
AlTiN - basierte Beschichtung

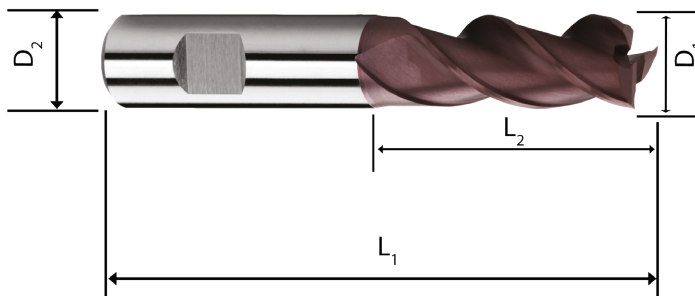

Technische Daten:	
Material:	HSS-Co8
Drallwinkel λ :	30°
Spanwinkel γ :	12°
Anzahl Schneiden:	3

Bestellnummer: SB(F) 0410 020
 beschichtet
 Ø Code
 Seitenspannfläche: 0410

Werkstoff:

Stahl	Inox	Gusseisen	Titan
Stahl bis R_m 1100 N/mm ²	Nichtrostender Stahl		CrNi

Performance:

●●●● ●●● ●● ●

Ø Code	D ₁ k10	D ₂ h6	L ₁	L ₂	z					AlTiN basiert SBF0410
020	2	6	51	7	3					9,30 €
025	2,5	6	52	8	3					9,30 €
030	3	6	52	8	3					9,30 €
035	3,5	6	54	10	3					9,30 €
040	4	6	55	11	3					9,30 €
045	4,5	6	55	11	3					9,30 €
050	5	6	57	13	3					9,30 €
055	5,5	6	57	13	3					9,30 €
060	6	6	57	13	3					9,30 €
065	6,5	10	66	16	3					13,02 €
075	7,5	10	66	16	3					13,02 €

Werkstoff	D_1 mm	z	V_c m/min	f mm/z	a_p mm	a_e mm	n u/min	V_f mm/min	
Stahl bis R_m 1100 N/mm² ●●●●									
	10	5	55	0,039	15	5	1751	341	
	12	5	55	0,044	18	6	1459	321	
	14	5	55	0,055	21	7	1251	344	
	16	5	55	0,077	24	8	1094	421	
	20	5	55	0,100	30	10	875	438	
Stahl bis R_m 1100 N/mm² ●●●●									
	10	5	50	0,039	15	5	1592	310	
	12	5	50	0,044	18	6	1326	292	
	14	5	50	0,055	21	7	1137	313	
	16	5	50	0,077	24	8	995	383	
	20	5	50	0,100	30	10	796	398	
Nichtrostender Stahl ●●●									
	10	5	35	0,039	15	5	1114	217	
	12	5	35	0,044	18	6	928	204	
	14	5	35	0,055	21	7	796	219	
	16	5	35	0,077	24	8	696	268	
	20	5	35	0,100	30	10	557	279	
Gusseisen <240 HB ●●●									
	10	5	65	0,039	15	5	2069	403	
	12	5	65	0,044	18	6	1724	379	
	14	5	65	0,055	21	7	1478	406	
	16	5	65	0,077	24	8	1293	498	
	20	5	65	0,100	30	10	1035	517	
CrNi-Legierungen <1500 N/mm² ●●									
	10	5	28	0,039	15	5	891	174	
	12	5	28	0,044	18	6	743	163	
	14	5	28	0,055	21	7	637	175	
	16	5	28	0,077	24	8	557	214	
	20	5	28	0,100	30	10	446	223	
Titan <1200 N/mm² ●●									
	10	5	26	0,039	15	5	828	161	
	12	5	26	0,044	18	6	690	152	
	14	5	26	0,055	21	7	591	163	
	16	5	26	0,077	24	8	517	199	
	20	5	26	0,100	30	10	414	207	

Schaftfräser HSS-E

SBF0609
AlTiN - basierte Beschichtung

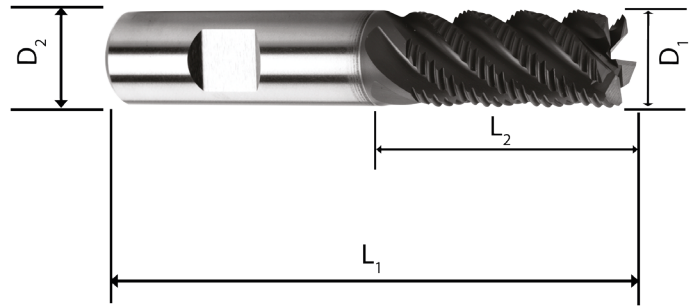

Technische Daten:	
Material:	HSS-Co8
Drallwinkel λ:	30°
Spanwinkel γ:	10°
Anzahl Schneiden:	5
Profil:	HR

Bestellnummer: SB(F) 0609 100
 beschichtet Ø Code
 Seitenspannfläche: 0609

Werkstoff:

Stahl	Inox	Gusseisen	Titan
Stahl bis R _m 1100 N/mm ²	Nichtrostender Stahl		CrNi

Performance:

●●●● ●●● ●●● ●●

Ø Code	D ₁ k12	D ₂ h6	L ₁	L ₂	z					AlTiN basiert SBF0609
100	10	10	72	22	5					25,03 €
110	11	12	79	22	5					28,12 €
120	12	12	83	26	5					28,12 €
140	14	12	83	26	5					38,28 €
160	16	16	92	32	5					40,78 €
180	18	16	92	32	5					53,22 €
200	20	20	104	38	5					61,77 €

Werkstoff	D_1 mm	z	V_c m/min	f mm/z	a_p mm	a_e mm	n u/min	V_f mm/min	
Stahl bis R_m 1100 N/mm² ●●●●									
	5	4	55	0,018	7,5	2,5	3502	252	
	6	4	55	0,022	9	3	2918	257	
	8	4	55	0,028	12	4	2188	245	
	10	4	55	0,039	15	5	1751	273	
	12	4	55	0,044	18	6	1459	257	
	16	4	55	0,077	24	8	1094	337	
	20	4	55	0,100	30	10	875	350	
	25	5	55	0,110	37,5	12,5	700	385	
Stahl bis R_m 1100 N/mm² ●●●●									
	5	4	51	0,018	7,5	2,5	3247	234	
	6	4	51	0,022	9	3	2706	238	
	8	4	51	0,028	12	4	2029	227	
	10	4	51	0,039	15	5	1623	253	
	12	4	51	0,044	18	6	1353	238	
	16	4	51	0,077	24	8	1015	313	
	20	4	51	0,100	30	10	812	325	
	25	5	51	0,110	37,5	12,5	649	357	
Nichtrostender Stahl ●●●									
	5	4	35	0,018	7,5	2,5	2228	160	
	6	4	35	0,022	9	3	1857	163	
	8	4	35	0,028	12	4	1393	156	
	10	4	35	0,039	15	5	1114	174	
	12	4	35	0,044	18	6	928	163	
	16	4	35	0,077	24	8	696	214	
	20	4	35	0,100	30	10	557	223	
	25	5	35	0,110	37,5	12,5	446	245	
Gusseisen ●●●									
	5	4	60	0,018	7,5	2,5	3820	275	
	6	4	60	0,022	9	3	3183	280	
	8	4	60	0,028	12	4	2387	267	
	10	4	60	0,039	15	5	1910	298	
	12	4	60	0,044	18	6	1592	280	
	16	4	60	0,077	24	8	1194	368	
	20	4	60	0,100	30	10	955	382	
	25	5	60	0,110	37,5	12,5	764	420	
CrNi-Legierungen < 1500 N/mm² ●●									
	5	4	28	0,018	7,5	2,5	1783	128	
	6	4	28	0,022	9	3	1485	131	
	8	4	28	0,028	12	4	1114	125	
	10	4	28	0,039	15	5	891	139	
	12	4	28	0,044	18	6	743	131	
	16	4	28	0,077	24	8	557	172	
	20	4	28	0,100	30	10	446	178	
	25	5	28	0,110	37,5	12,5	357	196	
Titan < 1200 N/mm² ●●									
	5	4	26	0,018	7,5	2,5	1655	119	
	6	4	26	0,022	9	3	1379	121	
	8	4	26	0,028	12	4	1035	116	
	10	4	26	0,039	15	5	828	129	
	12	4	26	0,044	18	6	690	121	
	16	4	26	0,077	24	8	517	159	
	20	4	26	0,100	30	10	414	166	
	25	5	26	0,110	37,5	12,5	331	182	

Schaftfräser HSS-E

SBF0610
AlTiN - basierte Beschichtung

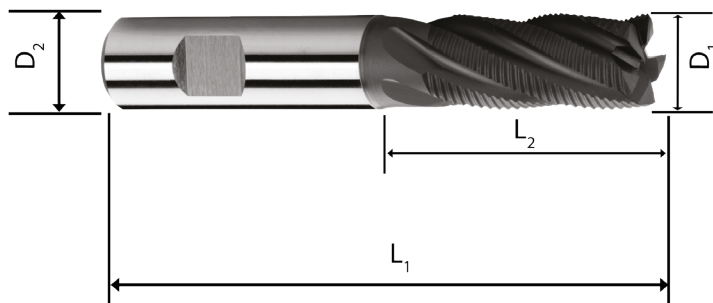

Technische Daten:	
Material:	HSS-Co8
Drallwinkel λ :	30°
Spanwinkel γ :	10°
Anzahl Schneiden:	4/5
Profil:	HR

Bestellnummer: SB(F) 0610 050
 beschichtet
 Ø Code
 Seitenspannfläche: 0610

Werkstoff:

Stahl	Inox	Gusseisen	Titan
Stahl bis R_m 1100 N/mm ²	Nichtrostender Stahl		CrNi
●●●●	●●●	●●●	●●●

Performance:

Ø Code	D_1 k12	D_2 h6	L_1	L_2	z					AlTiN basiert SBF0610
050	5	6	57	13	4					24,86 €
060	6	6	57	13	4					24,86 €
070	7	10	66	16	4					35,55 €
080	8	10	69	19	4					38,28 €
090	9	10	69	19	4					27,56 €
100	10	10	72	22	4					27,56 €
110	11	12	79	22	4					30,98 €
120	12	12	83	26	4					30,98 €
140	14	12	83	26	4					42,18 €
160	16	16	92	32	4					42,18 €
180	18	16	92	32	4					58,78 €
200	20	20	104	38	4					58,78 €
220	22	20	104	38	5					86,59 €
250	25	25	121	45	5					86,59 €

Werkstoff	D_1 mm	z	V_c m/min	f mm/z	a_p mm	a_e mm	n u/min	V_f mm/min	
Stahl bis R_m 1100 N/mm² ●●●●									
	6	4	60	0,022	9	3	3183	280	
	8	4	60	0,028	12	4	2387	267	
	10	4	60	0,039	15	5	1910	298	
	12	4	60	0,044	18	6	1592	280	
	16	4	60	0,077	24	8	1194	368	
	20	4	60	0,100	30	10	955	382	
	25	5	60	0,110	37,5	12,5	764	420	
	30	5	60	0,120	45	15	637	382	
Stahl bis R_m 1100 N/mm² ●●●●									
	6	4	50	0,022	9	3	2653	233	
	8	4	50	0,028	12	4	1989	223	
	10	4	50	0,039	15	5	1592	248	
	12	4	50	0,044	18	6	1326	233	
	16	4	50	0,077	24	8	995	306	
	20	4	50	0,100	30	10	796	318	
	25	5	50	0,110	37,5	12,5	637	350	
	30	5	50	0,120	45	15	531	318	
Nichtrostender Stahl ●●●									
	6	4	38	0,022	9	3	2016	177	
	8	4	38	0,028	12	4	1512	169	
	10	4	38	0,039	15	5	1210	189	
	12	4	38	0,044	18	6	1008	177	
	16	4	38	0,077	24	8	756	233	
	20	4	38	0,100	30	10	605	242	
	25	5	38	0,110	37,5	12,5	484	266	
	30	5	38	0,120	45	15	403	242	
Gusseisen <240 HB ●●●									
	6	4	65	0,022	9	3	3448	303	
	8	4	65	0,028	12	4	2586	290	
	10	4	65	0,039	15	5	2069	323	
	12	4	65	0,044	18	6	1724	303	
	16	4	65	0,077	24	8	1293	398	
	20	4	65	0,100	30	10	1035	414	
	25	5	65	0,110	37,5	12,5	828	455	
	30	5	65	0,120	45	15	690	414	
CrNi-Legierungen <1500 N/mm² ●●									
	6	4	32	0,022	9	3	1698	149	
	8	4	32	0,028	12	4	1273	143	
	10	4	32	0,039	15	5	1019	159	
	12	4	32	0,044	18	6	849	149	
	16	4	32	0,077	24	8	637	196	
	20	4	32	0,100	30	10	509	204	
	25	5	32	0,110	37,5	12,5	407	224	
	30	5	32	0,120	45	15	340	204	
Titan <1200 N/mm² ●●									
	6	4	30	0,022	9	3	1592	140	
	8	4	30	0,028	12	4	1194	134	
	10	4	30	0,039	15	5	955	149	
	12	4	30	0,044	18	6	796	140	
	16	4	30	0,077	24	8	597	184	
	20	4	30	0,100	30	10	477	191	
	25	5	30	0,110	37,5	12,5	382	210	
	30	5	30	0,120	45	15	318	191	

Schaftfräser HSS-E

SBF0619
AlTiN - basierte Beschichtung

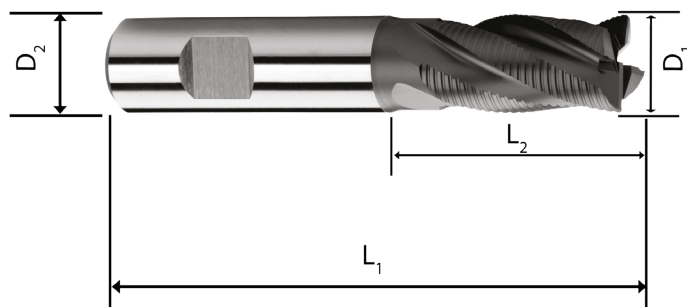

Technische Daten:	
Material:	HSS-Co8
Drallwinkel λ :	30°
Spanwinkel γ :	10°
Anzahl Schneiden:	4/5
Profil:	HR-F

Bestellnummer: SB(F) 0619 060
 beschichtet
 Ø Code
 Seitenspannfläche: 0619

Werkstoff:

Stahl	Inox	Gusseisen	Titan
Stahl bis R_m 1100 N/mm ²	Nichtrostender Stahl		CrNi
●●●●	●●●	●●	●●

Performance:

Ø Code	D ₁ k12	D ₂ h6	L ₁	L ₂	z					AlTiN basiert SBF0619
060	6	6	57	13	4					32,97 €
080	8	10	69	19	4					33,92 €
090	9	10	69	19	4					36,55 €
100	10	10	72	22	4					36,55 €
110	11	12	79	22	4					40,99 €
120	12	12	83	26	4					40,99 €
140	14	12	83	26	4					55,60 €
160	16	16	92	32	4					55,60 €
180	18	16	92	32	4					55,60 €
200	20	20	104	38	4					77,84 €
220	22	20	104	38	5					115,19 €
250	25	25	121	45	5					115,19 €

Werkstoff	D_1 mm	z	V_c m/min	f mm/z	a_p mm	a_e mm	n u/min	V_f mm/min	
Stahl bis R_m 1100 N/mm² ●●●									
	6	4	30	0,020	9	3	1592	127	
	8	4	30	0,025	12	4	1194	119	
	10	4	30	0,035	15	5	955	134	
	12	4	30	0,040	18	6	796	127	
	16	4	30	0,070	24	8	597	167	
	20	4	30	0,080	30	10	477	153	
	25	5	30	0,090	37,5	12,5	382	172	
Nichtrostender Stahl ●●●									
	6	4	38	0,022	9	3	2016	177	
	8	4	38	0,028	12	4	1512	169	
	10	4	38	0,039	15	5	1210	189	
	12	4	38	0,044	18	6	1008	177	
	16	4	38	0,077	24	8	756	233	
	20	4	38	0,100	30	10	605	242	
	25	5	38	0,110	37,5	12,5	484	266	
	30	5	38	0,120	45	15	403	242	
Gusseisen <240 HB ●●●									
	6	4	28	0,020	9	3	1485	119	
	8	4	28	0,025	12	4	1114	111	
	10	4	28	0,035	15	5	891	125	
	12	4	28	0,040	18	6	743	119	
	16	4	28	0,070	24	8	557	156	
	20	4	28	0,080	30	10	446	143	
	25	5	28	0,090	37,5	12,5	357	160	
Titan CrNi <1200 N/mm² ●●									
	6	4	30	0,022	9	3	1592	140	
	8	4	30	0,028	12	4	1194	134	
	10	4	30	0,039	15	5	955	149	
	12	4	30	0,044	18	6	796	140	
	16	4	30	0,077	24	8	597	184	
	20	4	30	0,100	30	10	477	191	
	25	5	30	0,110	37,5	12,5	382	210	
	30	5	30	0,120	45	15	318	191	

Werkstoff	D_1 mm	z	V_c m/min	f mm/z	a_p mm	a_e mm	n u/min	V_f mm/min	
Stahl bis R_m 1100 N/mm² ●●●●									
	6	4	42	0,022	9	3	2228	196	
	8	4	42	0,028	12	4	1671	187	
	10	4	42	0,039	15	5	1337	209	
	12	4	42	0,044	18	6	1114	196	
	16	4	42	0,077	24	8	836	257	
	20	4	42	0,100	30	10	668	267	
Stahl bis R_m 1100 N/mm² ●●●●									
	6	4	38	0,022	9	3	2016	177	
	8	4	38	0,028	12	4	1512	169	
	10	4	38	0,039	15	5	1210	189	
	12	4	38	0,044	18	6	1008	177	
	16	4	38	0,077	24	8	756	233	
	20	4	38	0,100	30	10	605	242	
Nichtrostender Stahl ●●●									
	6	4	28	0,022	9	3	1485	131	
	8	4	28	0,028	12	4	1114	125	
	10	4	28	0,039	15	5	891	139	
	12	4	28	0,044	18	6	743	131	
	16	4	28	0,077	24	8	557	172	
	20	4	28	0,100	30	10	446	178	
Gusseisen <240 HB ●●●									
	6	4	45	0,022	9	3	2387	210	
	8	4	45	0,028	12	4	1791	201	
	10	4	45	0,039	15	5	1432	223	
	12	4	45	0,044	18	6	1194	210	
	16	4	45	0,077	24	8	895	276	
	20	4	45	0,100	30	10	716	286	
CrNi-Legierungen <1500 N/mm² ●●									
	6	4	22	0,022	9	3	1167	103	
	8	4	22	0,028	12	4	875	98	
	10	4	22	0,039	15	5	700	109	
	12	4	22	0,044	18	6	584	103	
	16	4	22	0,077	24	8	438	135	
	20	4	22	0,100	30	10	350	140	
CrNi-Legierungen <1500 N/mm² ●●									
	6	4	22	0,022	9	3	1167	103	
	8	4	22	0,028	12	4	875	98	
	10	4	22	0,039	15	5	700	109	
	12	4	22	0,044	18	6	584	103	
	16	4	22	0,077	24	8	438	135	
	20	4	22	0,100	30	10	350	140	

Schaftfräser HSS-E

SBF0665
AlTiN - basierte Beschichtung

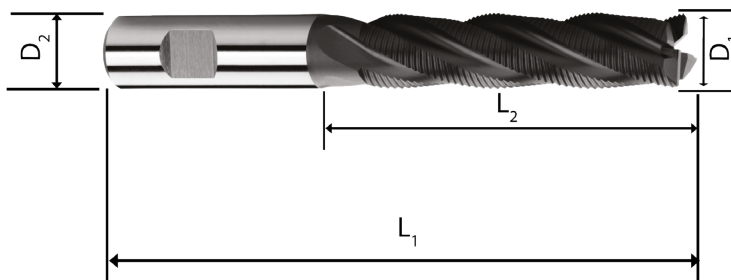

Technische Daten:	
Material:	HSS-Co8
Drallwinkel λ :	30°
Spanwinkel γ :	10°
Anzahl Schneiden:	4
Profil:	HR

Bestellnummer: SB(F) 0665 060
 beschichtet
 Ø Code
 Seitenspannfläche: 0665

Werkstoff:

Stahl	Inox	Gusseisen	Titan
Stahl bis R_m 1100 N/mm ²	Nichtrostender Stahl		CrNi
●●●●	●●●	●●●	●●

Performance:

Ø Code	D ₁ k12	D ₂ h6	L ₁	L ₂	z					AlTiN basiert SBF0665
060	6	6	68	24	4					34,56 €
080	8	10	88	38	4					35,58 €
100	10	10	95	45	4					38,28 €
120	12	12	110	53	4					42,97 €
140	14	12	110	53	4					58,78 €
160	16	16	123	63	4					58,78 €
180	18	16	123	63	4					81,81 €
200	20	20	141	75	4					81,81 €

SBF03400

Werkstoff	D ₁ mm	z	V _c m/min	f mm/z	a _p mm	a _e mm	n u/min	V _f mm/min	
Stahl bis R_m 1000 N/mm² ●●●●									
	40	6	50	0,075	8,0	30,0	400	180	
	50	8	50	0,095	10,0	37,5	320	245	
	63	8	50	0,095	12,6	47,3	255	195	
	80	10	50	0,120	16,0	60,0	200	240	
Stahl bis R_m 1200 N/mm² ●●●●									
	40	6	36	0,075	8,0	30,0	285	130	
	50	8	36	0,095	10,0	37,5	230	175	
	63	8	36	0,095	12,6	47,3	180	135	
	80	10	36	0,120	16,0	60,0	145	175	
Nichtrostender Stahl ●									
	40	6	15	0,096	8,0	30,0	125	72	
	50	8	15	0,096	10,0	37,5	100	76	
	63	8	15	0,096	12,6	47,3	75	58	
	80	10	15	0,096	16,0	60,0	60	58	
Gusseisen ●●									
	40	6	45	0,075	8,0	30,0	360	160	
	50	8	45	0,095	10,0	37,5	285	215	
	63	8	45	0,095	12,6	47,3	225	170	
	80	10	45	0,120	16,0	60,0	180	215	

Walzenstirnfräser

SBF03400
TiALN - basierte Beschichtung

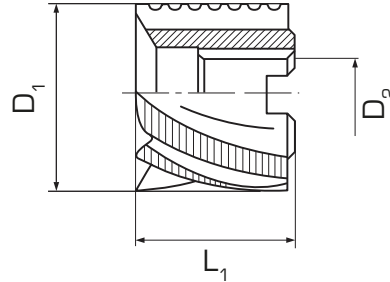

Technische Daten:

Material:	HSS-Co5
Drallwinkel λ :	30°
Spanwinkel Υ :	12°
Profil:	NR
Anzahl Schneiden:	6/8/10

Bestellnummer: SB(F) 03400 040
 beschichtet | Ø Code

Werkstoff:

Stahl
Stahl bis R_m 1000 N/mm²
Inox
Nichtrostender Stahl
Gusseisen

Performance:



Ø Code	D_1 js16	D_2 h7	L_1	z						TiALN basiert SBF03400
040	40	16	32	6						130,25 €
050	50	22	36	6						159,21 €
063	63	27	40	8						201,50 €
080	80	27	45	8						275,55 €
100	100	40	50	10						421,73 €

Werkstoff	D_1 mm	z	V_c m/min	f mm/z	a_p mm	a_e mm	n u/min	V_f mm/min	
Aluminium ●●●●									
	40	4	150	0,060	4,0	30,0	1195	285	
	50	5	150	0,075	5,0	37,5	955	360	
	63	5	150	0,115	6,3	47,3	760	435	
	80	6	150	0,145	8,0	60,0	595	520	
Aluminium - Si <6% ●●●●									
	40	4	200	0,060	4,0	30,0	1590	380	
	50	5	200	0,075	5,0	37,5	1275	480	
	63	5	200	0,115	6,3	47,3	1010	580	
	80	6	200	0,145	8,0	60,0	795	690	
Kupfer ●●●●									
	40	4	70	0,060	4,0	30,0	555	135	
	50	5	70	0,075	5,0	37,5	445	165	
	63	5	70	0,115	6,3	47,3	355	205	
	80	6	70	0,145	8,0	60,0	280	245	
Termoplaste ●●●									
	40	4	250	0,060	4,0	30,0	1990	480	
	50	5	250	0,075	5,0	37,5	1590	595	
	63	5	250	0,115	6,3	47,3	1265	725	
	80	6	250	0,145	8,0	60,0	995	865	

Walzenstirnfräser

SB03000

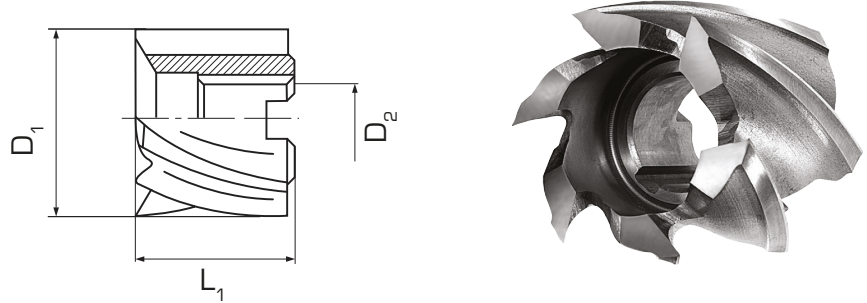

Technische Daten:	
Material:	HSS-Co5
Drallwinkel λ :	40°
Spanwinkel γ :	22°
Anzahl Schneiden:	4/5/6/7
Profil:	W

Bestellnummer: SB 03000 040
 unbeschichtet | | Ø Code

Werkstoff:

Aluminium Nichteisenwerkstoffe	Kupfer	Thermoplaste
--	---------------	---------------------

Performance:

●●●● ●●●● ●●●

Ø Code	D ₁ js16	D ₂ H7	L ₁	z							SB03000 unbeschichtet
040	40	16	32	4							79,17 €
050	50	22	36	4							104,62 €
063	63	27	40	5							141,39 €
080	80	27	45	6							241,26 €
100	100	32	50	7							360,48 €

SBF03200

Werkstoff	D ₁ mm	z	V _c m/min	f mm/z	a _p mm	a _e mm	n u/min	V _f mm/min	
Stahl bis R_m 1000 N/mm² ●●●●									
	40	6	50	0,065	2,0	30,0	400	155	
	50	8	50	0,080	2,5	37,5	320	205	
	63	8	50	0,080	3,2	47,3	255	165	
	80	10	50	0,100	4,0	60,0	200	200	
Stahl bis R_m 1200 N/mm² ●●●●									
	40	6	36	0,065	2,0	30,0	285	110	
	50	8	36	0,080	2,5	37,5	230	145	
	63	8	36	0,080	3,2	47,3	180	115	
	80	10	36	0,100	4,0	60,0	145	145	
Nichtrostender Stahl ●●									
	40	6	10	0,065	2,0	30,0	85	33	
	50	8	10	0,080	2,5	37,5	65	41	
	63	8	10	0,080	3,2	47,3	50	32	
	80	10	10	0,100	4,0	60,0	40	60	
Gusseisen ●●									
	40	6	45	0,065	2,0	30,0	360	140	
	50	8	45	0,080	2,5	37,5	285	180	
	63	8	45	0,080	3,2	47,3	225	145	
	80	10	45	0,10	4,0	60,0	180	180	

Walzenstirnfräser

SBF03200
TiALN - basierte Beschichtung

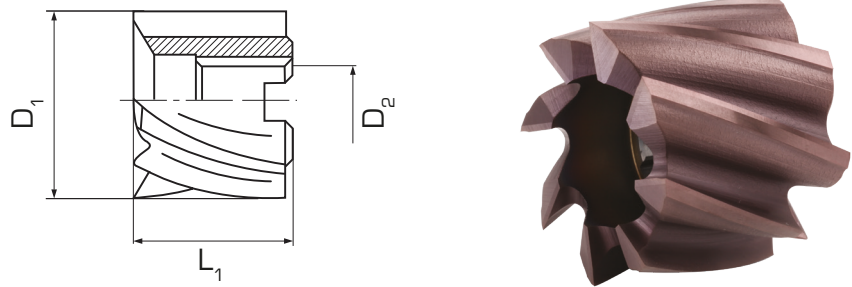

Technische Daten:	
Material:	HSS-Co5
Drallwinkel λ :	30°
Spanwinkel γ :	12°
Anzahl Schneiden:	6/8/10/14
Profil:	N

Bestellnummer: SB(F) 03200 040
 beschichtet | | Ø Code

Werkstoff:

Stahl	Inox	Gusseisen
Stahl bis R_m 1350 N/mm ²	Nichtrostender Stahl	

Performance:

●●●● ●● ●●

Ø Code	D ₁ js16	D ₂ h7	L ₁	z						TiALN basiert SBF03200
040	40	16	32	6						96,07 €
050	50	22	36	8						118,70 €
063	63	27	40	8						158,06 €
080	80	27	45	10						224,71 €
100	100	32	50	10						348,93 €
125	125	40	56	14						470,62 €

Werkstoff	D ₁ mm	S	V _c m/min	f mm/z	a _p mm	a _e mm	n u/min	V _f mm/min	z
Stahl bis R_m <600 N/mm² ●●●●									
	50	3/4/5/6/8/10	37,5	0,05	5,00	1xS	250	150	12
	63	3/4/5/6/8/10/12/14/16/18	37,5	0,06	6,30	1xS	200	144	12
	80	3/4/5/6/8/10/12/14/16/18/20	37,5	0,07	8,00	1xS	155	152	14
	100	3/4/5/6/8/10/12/14/16/18/20/22/25	37,5	0,08	10,00	1xS	125	140	14
	125	4/5/6/8/10/12/14/16/18/20/22/25/28	37,5	0,09	12,50	1xS	95	137	16
	160	6/8/10/12/14/18/20/25/32	37,5	0,092	16,00	1xS	75	124	18
	200	8/10/12/14/16/18/20/25/32	37,5	0,095	20,00	1xS	60	137	24
Nichtrostender Stahl ●									
	50	3/4/5/6/8/10	10	0,05	5,00	1xS	65	39	12
	63	3/4/5/6/8/10/12/14/16/18	10	0,06	6,30	1xS	50	36	12
	80	3/4/5/6/8/10/12/14/16/18/20	10	0,07	8,00	1xS	40	39	14
	100	3/4/5/6/8/10/12/14/16/18/20/22/25	10	0,08	10,00	1xS	32	36	14
	125	4/5/6/8/10/12/14/16/18/20/22/25/28	10	0,09	12,50	1xS	25	36	16
	160	6/8/10	10	0,092	16,00	1xS	20	33	18
	200	8/10/12/14/16/18/20/25/32	10	0,095	20,00	1xS	16	36	24
Gusseisen ●●									
	50	3/4/5/6/8/10	30	0,05	5,00	1xS	200	120	12
	63	3/4/5/6/8/10/12/14/16/18	30	0,06	6,30	1xS	160	115	12
	80	3/4/5/6/8/10/12/14/16/18/20	30	0,07	8,00	1xS	125	123	14
	100	3/4/5/6/8/10/12/14/16/18/20/22/25	30	0,08	10,00	1xS	95	106	14
	125	4/5/6/8/10/12/14/16/18/20/22/25/28	30	0,09	12,50	1xS	75	108	16
	160	6/8/10	30	0,092	16,00	1xS	60	99	18
	200	8/10/12/14/16/18/20/25/32	30	0,095	20,00	1xS	50	114	24
Aluminium ●●									
	50	3/4/5/6/8/10	80	0,05	5,00	1xS	530	318	12
	63	3/4/5/6/8/10/12/14/16/18	80	0,06	6,30	1xS	420	302	12
	80	3/4/5/6/8/10/12/14/16/18/20	80	0,07	8,00	1xS	330	323	14
	100	3/4/5/6/8/10/12/14/16/18/20/22/25	80	0,08	10,00	1xS	250	280	14
	125	4/5/6/8/10/12/14/16/18/20/22/25/28	80	0,09	12,50	1xS	200	288	16
	160	6/8/10	80	0,092	16,00	1xS	160	265	18
	200	8/10/12/14/16/18/20/25/32	80	0,095	20,00	1xS	130	296	24

Scheibenfräser

SB05000

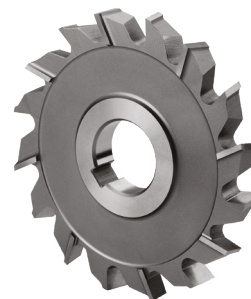
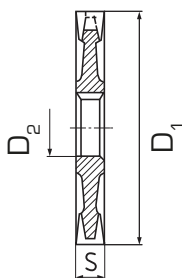

Technische Daten:	
Material:	HSS-Co5
Drallwinkel λ :	10°
Spanwinkel γ :	12°
Anzahl Schneiden:	12/14
Profil:	H

Bestellnummer: SB 05000 0500316
 unbeschichtet | Ø Code

Werkstoff:

Stahl	Inox	Gusseisen	Aluminium
Stahl bis Rm 600 N/mm ²	Nichtrostender Stahl		Nichteisenwerkstoffe

Performance:

●●●● ● ●● ●●

Ø Code	D ₁ js16	D ₂ H7	s k11			z				SB05000 unbeschichtet
0500316	50	16	3			12				49,36 €
0500416	50	16	4			12				49,36 €
0500516	50	16	5			12				50,04 €
0500616	50	16	6			12				50,85 €
0500816	50	16	8			12				56,65 €
0501016	50	16	10			12				60,90 €
0630322	63	22	3			12				60,56 €
0630422	63	22	4			12				53,55 €
0630522	63	22	5			12				57,05 €
0630622	63	22	6			12				59,30 €
0630822	63	22	8			12				61,88 €
0631022	63	22	10			12				69,69 €
0631222	63	22	12			12				78,43 €
0631422	63	22	14			12				88,89 €
0631622	63	22	16			12				93,65 €
0631822	63	22	18			12				98,37 €
0800327	80	27	3			14				73,14 €
0800427	80	27	4			14				69,76 €
0800527	80	27	5			14				72,28 €
0800627	80	27	6			14				74,00 €
0800827	80	27	8			14				78,43 €
0801027	80	27	10			14				80,32 €
0801227	80	27	12			14				90,49 €
0801427	80	27	14			14				105,84 €
0801627	80	27	16			14				112,33 €
0801827	80	27	18			14				130,60 €
0802027	80	27	20			14				139,74 €
1000332	100	32	3			14				91,47 €
1000432	100	32	4			14				87,10 €
1000532	100	32	5			14				88,37 €
1000632	100	32	6			14				96,47 €
1000832	100	32	8			14				105,77 €

Werkstoff	D ₁ mm	S	V _c m/min	f mm/z	a _p mm	a _e mm	n u/min	V _f mm/min	z
Stahl bis R_m <600 N/mm² ●●●●									
	50	3/4/5/6/8/10	37,5	0,05	5,00	1xS	250	150	12
	63	3/4/5/6/8/10/12/14/16/18	37,5	0,06	6,30	1xS	200	144	12
	80	3/4/5/6/8/10/12/14/16/18/20	37,5	0,07	8,00	1xS	155	152	14
	100	3/4/5/6/8/10/12/14/16/18/20/22/25	37,5	0,08	10,00	1xS	125	140	14
	125	4/5/6/8/10/12/14/16/18/20/22/25/28	37,5	0,09	12,50	1xS	95	137	16
	160	6/8/10/12/14/18/20/25/32	37,5	0,092	16,00	1xS	75	124	18
	200	8/10/12/14/16/18/20/25/32	37,5	0,095	20,00	1xS	60	137	24
Nichtrostender Stahl ●									
	50	3/4/5/6/8/10	10	0,05	5,00	1xS	65	39	12
	63	3/4/5/6/8/10/12/14/16/18	10	0,06	6,30	1xS	50	36	12
	80	3/4/5/6/8/10/12/14/16/18/20	10	0,07	8,00	1xS	40	39	14
	100	3/4/5/6/8/10/12/14/16/18/20/22/25	10	0,08	10,00	1xS	32	36	14
	125	4/5/6/8/10/12/14/16/18/20/22/25/28	10	0,09	12,50	1xS	25	36	16
	160	6/8/10	10	0,092	16,00	1xS	20	33	18
	200	8/10/12/14/16/18/20/25/32	10	0,095	20,00	1xS	16	36	24
Gusseisen ●●									
	50	3/4/5/6/8/10	30	0,05	5,00	1xS	200	120	12
	63	3/4/5/6/8/10/12/14/16/18	30	0,06	6,30	1xS	160	115	12
	80	3/4/5/6/8/10/12/14/16/18/20	30	0,07	8,00	1xS	125	123	14
	100	3/4/5/6/8/10/12/14/16/18/20/22/25	30	0,08	10,00	1xS	95	106	14
	125	4/5/6/8/10/12/14/16/18/20/22/25/28	30	0,09	12,50	1xS	75	108	16
	160	6/8/10	30	0,092	16,00	1xS	60	99	18
	200	8/10/12/14/16/18/20/25/32	30	0,095	20,00	1xS	50	114	24
Aluminium ●●									
	50	3/4/5/6/8/10	80	0,05	5,00	1xS	530	318	12
	63	3/4/5/6/8/10/12/14/16/18	80	0,06	6,30	1xS	420	302	12
	80	3/4/5/6/8/10/12/14/16/18/20	80	0,07	8,00	1xS	330	323	14
	100	3/4/5/6/8/10/12/14/16/18/20/22/25	80	0,08	10,00	1xS	250	280	14
	125	4/5/6/8/10/12/14/16/18/20/22/25/28	80	0,09	12,50	1xS	200	288	16
	160	6/8/10	80	0,092	16,00	1xS	160	265	18
	200	8/10/12/14/16/18/20/25/32	80	0,095	20,00	1xS	130	296	24

Scheibenfräser

SB05000

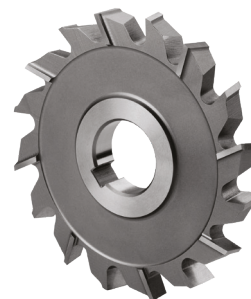
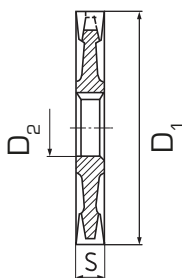

Bestellnummer: SB 05000 1001032
 unbeschichtet | Ø Code

Technische Daten:	
Material:	HSS-Co5
Drallwinkel λ :	10°
Spanwinkel γ :	12°
Anzahl Schneiden:	14/16/18
Profil:	H

Werkstoff:

Stahl	Inox	Gusseisen	Aluminium
Stahl bis Rm 600 N/mm²	Nichtrostender Stahl		Nichteisenwerkstoffe

Performance:

●●●● ● ●● ●●

Ø Code	D ₁ js16	D ₂ H7	s k11		z				SB05000 unbeschichtet
1001032	100	32	10		14				111,87 €
1001232	100	32	12		14				120,66 €
1001432	100	32	14		14				134,56 €
1001632	100	32	16		14				141,92 €
1001832	100	32	18		14				166,79 €
1002032	100	32	20		14				165,02 €
1002232	100	32	22		14				212,82 €
1002532	100	32	25		14				213,33 €
1250432	125	32	4		16				107,44 €
1250532	125	32	5		16				111,12 €
1250632	125	32	6		16				118,36 €
1250832	125	32	8		16				131,52 €
1251032	125	32	10		16				148,47 €
1251232	125	32	12		16				161,11 €
1251432	125	32	14		16				181,56 €
1251632	125	32	16		16				191,50 €
1251832	125	32	18		16				207,65 €
1252032	125	32	20		16				221,26 €
1252232	125	32	22		16				234,59 €
1252532	125	32	25		16				267,29 €
1252832	125	32	28		16				283,31 €
1600640	160	40	6		18				171,85 €
1600840	160	40	8		18				194,78 €
1601040	160	40	10		18				218,96 €

Werkstoff	D ₁ mm	z	V _c m/min	f mm/z	a _p mm	a _e mm	n u/min	V _f mm/min	
Aluminium									••••
Si < 6%	6	3	165	0,026	9	3	9000	702	
	8	3	165	0,035	12	4	6800	714	
	10	3	165	0,044	15	5	4800	634	
	12	3	165	0,053	18	6	4500	716	
	16	3	165	0,070	24	8	3400	714	
	20	3	165	0,088	30	10	2600	686	

Schaftfräser

SB03910

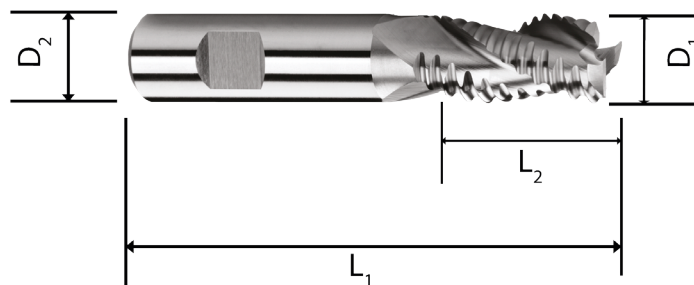

Technische Daten:	
Material:	HSS-Co8
Drallwinkel λ :	35°
Spanwinkel γ :	18°
Anzahl Schneiden:	3
Profil:	WR

Bestellnummer: SB 03910 060
 unbeschichtet Ø Code
 Seitenspannfläche: 03910

Werkstoff:

Aluminium
Nichteisenwerkstoffe

Performance: ●●●●

Ø Code	D ₁ k12	D ₂ h6	L ₁	L ₂	z					SB03910 unbeschichtet
060	6	6	57	13	3					18,34 €
080	8	10	69	19	3					20,11 €
100	10	10	72	22	3					22,95 €
120	12	12	83	26	3					26,97 €
160	16	16	92	32	3					37,96 €
200	20	20	104	38	3					56,36 €
250	25	25	121	45	3					95,82 €
300	30	25	121	45	3					143,66 €

Werkstoff	D ₁ mm	z	V _c m/min	f mm/z	a _p mm	a _e mm	n u/min	V _f mm/min	
Aluminium									••••
Si < 6%	6	3	165	0,026	9	3	9000	702	
	8	3	165	0,035	12	4	6800	714	
	10	3	165	0,044	15	5	4800	634	
	12	3	165	0,053	18	6	4500	716	
	16	3	165	0,070	24	8	3400	714	
	20	3	165	0,088	30	10	2600	686	

SB03930

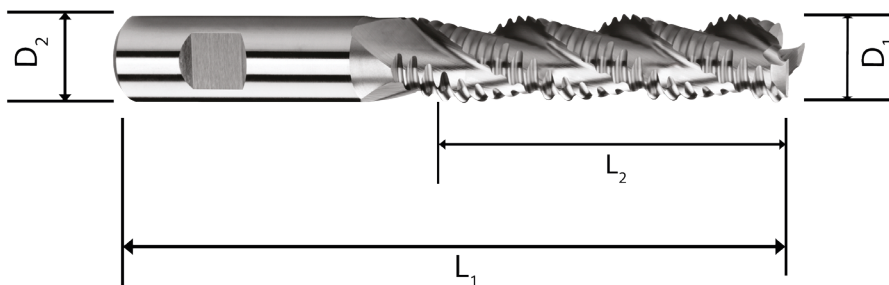

Technische Daten:	
Material:	HSS-Co8
Drallwinkel λ :	35°
Spanwinkel γ :	18°
Anzahl Schneiden:	3
Profil:	WR

Bestellnummer: SB 03930 060
 unbeschichtet | | \emptyset Code
 Seitenspannfläche: 03930

Werkstoff:

Aluminium
Nichteisenwerkstoffe

Performance: ●●●●

\emptyset Code	D_1 k8	D_2 h6	L_1	L_2	z						SB03930 unbeschichtet
060	6	6	68	24	3						21,45 €
080	8	10	88	38	3						25,58 €
100	10	10	95	45	3						26,97 €
120	12	12	110	53	3						31,54 €
160	16	16	123	63	3						44,72 €
200	20	20	141	75	3						66,45 €

Zapfensenker

SB08000

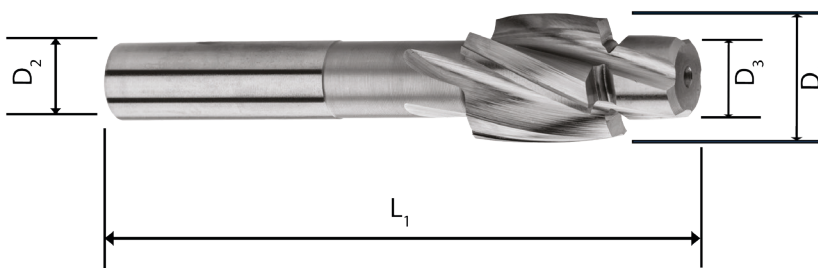

Technische Daten:	
Material:	HSS-Co5
DIN:	373
Winkel:	180°
Anzahl Schneiden:	3

Bestellnummer: SB 08000 0430160
 unbeschichtet | Ø Code
 Glattschaft:: 08000

Werkstoff:

Stahl	Inox	Aluminium	Gusseisen	Titan
Stahl bis R_m 1100 N/mm ²	Nichtrostender Stahl	Nichteisenwerkstoffe		

Performance:

●●●● ●●● ●●● ●●● ●

Ø Code	D_1 z9	D_2 h9	D_3	l_1	Gewinde d. Schraub	Z				SB08000 unbeschichtet
0430160	4,3	4,3	1,6	56	M2	3				22,80 €
0430250	4,3	4,3	2,5	56	M3	3				22,80 €
0500205	5	5	2,05	71	M2,5	3				22,80 €
0500270	5	5	2,7	71	M2,5	3				22,80 €
0600250	6	5	2,5	71	M3	3				19,49 €
0600320	6	5	3,2	71	M3	3				19,49 €
0650290	6,5	5	2,9	71	M3,5	3				21,76 €
0650370	6,5	5	3,7	71	M3,5	3				21,76 €
0800330	8	5	3,3	71	M4	3				24,27 €
0800430	8	5	4,3	71	M4	3				24,27 €
0800450	8	5	4,5	71	M4	3				24,27 €
1000420	10	8	4,2	80	M5	3				27,15 €
1000530	10	8	5,3	80	M5	3				27,15 €
1000550	10	8	5,5	80	M5	3				27,15 €
1100500	11	8	5	80	M6	3				27,40 €
1100640	11	8	6,4	80	M6	3				27,40 €
1500680	15	12,5	6,8	100	M8	3				39,41 €
1500840	15	12,5	8,4	100	M8	3				39,41 €
1500900	15	12,5	9	100	M8	3				39,41 €
1800850	18	12,5	8,5	100	M10	3				50,25 €
1801050	18	12,5	10,5	100	M10	3				50,25 €
1801100	18	12,5	11	100	M10	3				50,25 €
2001020	20	12,5	10,2	100	M12	3				54,54 €
2001300	20	12,5	13	100	M12	3				54,54 €
2001400	20	12,5	14	100	M12	3				54,54 €

Zentrierbohrer

SB07000

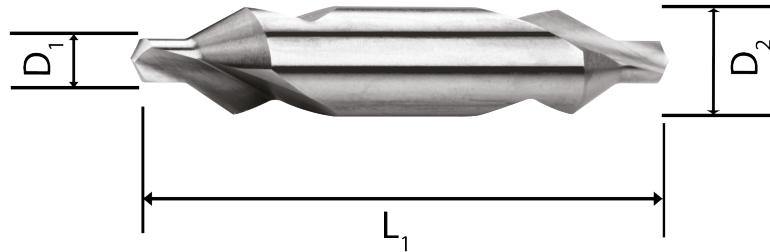

Technische Daten:

Material: HSS-Co5

Form: A

Profil: N

Bestellnummer: SB 07000 0100
 unbeschichtet
 Ø Code

Glattschaft: 07000

Werkstoff:

Stahl <small>Stahl bis R_m 1100 N/mm²</small>	Aluminium <small>Nichteisenwerkstoffe</small>	Gusseisen
---	---	------------------

Performance:

●●●● ●●● ●●

Ø Code	D_1 k12	D_2 h9	L_1								SB07000 unbeschichtet
100	1	3,15	31								7,60 €
125	1,25	3,15	31								7,60 €
160	1,6	4	35								7,66 €
200	2	5	40								8,46 €
250	2,5	6,3	45								9,62 €
315	3,15	8	50								11,03 €
400	4	10	55								14,03 €
500	5	12,5	63								22,67 €

Härtevergleichstabelle HV/HRC/Rm

R _m [N/mm ²]	HV 10	HB	HRC
240	75	71	-
255	80	76	-
270	85	81	-
285	90	86	-
305	95	90	-
320	100	95	-
335	105	100	-
350	110	105	-
370	115	109	-
385	120	114	-
400	125	119	-
415	130	124	-
430	135	128	-
450	140	133	-
465	145	138	-
480	150	143	-
495	155	147	-
510	160	152	-
530	165	157	-
545	170	162	-
560	175	166	-
575	180	171	-
595	185	176	-
610	190	181	-
625	195	185	-
640	200	190	-
660	205	195	-
675	210	199	-
690	215	204	-
705	220	209	-
720	225	214	-
740	230	219	-
755	235	223	-
770	240	228	-
785	245	233	-
800	250	238	-
820	255	242	-
835	260	247	-
860	268	255	-
870	272	258	-
900	280	266	-

R _m [N/mm ²]	HV 10	HB	HRC
920	287	273	28
940	293	278	29
970	302	287	30
995	310	295	31
1020	317	301	32
1050	327	311	33
1080	336	319	34
1110	345	328	35
1140	355	337	36
1170	364	346	37
1200	373	354	38
1230	382	363	39
1260	392	372	40
1300	403	383	41
1330	413	393	42
1360	423	402	43
1400	434	413	44
1440	446	424	45
1480	458	435	46
1530	473	449	47
1570	484	460	48
1620	497	472	49
1680	514	488	50
1730	527	501	51
1790	544	517	52
1845	560	532	53
1910	578	549	54
1980	596	567	55
2050	615	584	56
2140	639	607	57
-	655	622	58
-	675	-	59
-	698	-	60
-	720	-	61
-	745	-	62
-	773	-	63
-	800	-	64
-	829	-	65
-	864	-	66
-	900	-	67
-	940	-	68

Werkstoff-/ Zerspanungsgruppe		Brinell-Härte HB	Zugfestigkeit R _m	W.-Nr. DIN	DIN EN	
P	Unlegierter Stahl	P1	125	430	1.0401	C15
		P2	190	640	1.0503	C45
		P3	210	710	1.5423	16Mo5
		P4	190	640	1.0535	C55
					1.0601	C60
		P5	300	1010	1.0601	C60
	P6	220	750	1.0737	11SMnPb37	
	Niedrig legierter Stahl	P7	175	590	1.1167	36Mn5
					1.7223	41CrMo4
					1.7361	32CrMo12
					1.2713	55NiCrMoV6
		P8	285	960	1.6957	35NiCrMoV12-5
					1.7218	25CrMo4
					1.8928	S690QL
		P9	380	1280	1.6546	40NiCrMo2-2, 40NiCrMo2KD
1.7045					42Cr4	
1.7223					41CrMo4	
P10	430	1480	1.8933	S960QL		
			1.7361	32CrMo12		
Hochlegierter (Werkzeug-) Stahl	P11	200	680	1.2713	55NiCrMoV6	
				1.3401	X120Mn12	
	1.5680	X12Ni5, 12Ni19				
P13	380	1280	1.2580	X30WCrV9-3		
Nichtrostender Stahl	P14	200	680	1.4000	X6Cr13	
				1.4057	X19CrNi17-2, X17CrNi16-2	
M	Nichtrostender Stahl	M1	200	680	1.4301	X5CrNi18-10
					1.4308	GX5CrNi19-10
					1.4438	X2CrNiMo18-15-4
					1.4550	X6CrNiNb18-10
		M2	300	1010	1.4871	X53CrMnNiN21-9
		M3	230	780	1.4362	X2CrNiN23-4
1.4404	X2CrNiMoV12-5					
K	Temperguss	K1	200	400	0.8035	GTW-35-04, EN-GJMW-350-4
		K2	260	700	0.8170	EN-GJMB 700-2, GTS-70-02
	Grauguss	K3	180	200	0.6010	EN-GJL-100
					0.6020	EN-GJL-200
					0.6040	EN-GJL-400
	Gusseisen mit Kugelgraphit	K5	155	400	0.7040	EN-GJS-400-15
					0.7070	EN-GJS-700-2, EN-GJS-700-2U
GGV (CGI)	K7	230	400		EN-GJV-450	

Werkstoff-/ Zerspanungsgruppe		Brinell-Härte HB	Zugfestigkeit R _m	W.-Nr. DIN	DIN EN	
N	Aluminium - Knetlegierungen	N1	30	-	3.0255	Al99.5
		N2	100	340	3.1655	AlCu4Mg1.5Ni2, WL 3.17344
	Aluminium - Gusslegierungen	N3	75	260	3.3561	G-AlMg5
		N4	90	310	3.1371	G-AlCu4TiMg
					3.2371	G-AlSi7Mg, AlSi7Mg
	N5	130	450	3.5101	EN-MCMgZn4RE1Zr, G-MgZn4SE1Zr1	
	Magnesiumlegierungen	N6	70	250	3.5200	MgMn2
					3.5812	G-MgAl8Zn1
	Kupfer und Kupferlegierungen (Bronze/Messing)	N7	100	340	2.0240	CuZn15
					2.0966	CuAl10Ni5Fe4
N8		90	310	2.0321	CuZn37	
N9		110	380	2.1090	CuSn7Zn4Pb7-C	
N10	300	1010		CuAl13Fr4.5		
S	Warmfeste Legierungen	S1	200	680		
		S2	280	940		
		S3	250	840	2.4360	NiCu30
					2.4856	NiCr22MoSNb
		S4	350	1180	2.4375	NiCu30Al3Ti
	S5	320	1080			
	Titanlegierungen	S6	200	680	3.7025	Ti99.8
		S7	375	1260	3.7165	TiAl6V4
		S8	140	1400		
	Wolframlegierungen	S9	300	1010		
Molybdänlegierungen	S10	300	1010			
H	Gehärteter Stahl	H1	50 HRC			
		H2	55 HRC			
		H3	60 HRC			
	Gehärtetes Gusseisen	H4	55 HRC		0.9540	GX300CrMoNi15-2-1
				0.9620	GX260NCr42	
O	Thermoplaste	O1				
	Duroplaste	O2				
	Kunststoff, glasfaserverstärkt	O3				
	Kunststoff, kohlefaserverstärkt	O4				
Kunststoff, aramidfaserverstärkt	O5					
Graphit (technisch)	O6	80 Shore				

Technische Informationen		
D_1	Schneidendurchmesser	(mm)
D_2	Schaft- oder Bohrungsdurchmesser	(mm)
D_3	Halsdurchmesser	(mm)
L_1	Gesamtlänge des Werkzeugs	(mm)
L_2	Schneidenlänge	(mm)
L_3	Abstand von der Stirn des Werkzeugs bis zum Ende des Halses	(mm)
L_5	Schaftlänge	(mm)
L_c	Empfohlene maximale Bohrtiefe	(mm)
$b_{\alpha 45^\circ}$	Größe des Schutzfases zwischen Stirnschneide und Umfangschneide	(mm)
R	Radius	(mm)
z	Anzahl Schneiden	-
a_p	Zustelltiefe axial	(mm)
a_e	Zustelltiefe radial	(mm)
V_c	Schnittgeschwindigkeit	(m/min)
f	Vorschub pro Umdrehung	(mm/u)
f_z	Vorschub pro Zahn	(mm)
n	Drehzahl	(1/min)
V_f	Vorschubgeschwindigkeit	(mm/min)
Q	Zeitspanvolumen	(cm ³ /min)
HM 30	Feinstkornhartmetall 10% Cobalt - Anteil	-
λ	Drallwinkel	°
γ	Spanwinkel	°
	Stahl, Stahlguss, Werkzeugstahl	
	Inox nichtrostender Stahl, austenitisch, ferritisch	
	Aluminium und Nichteisenwerkstoffe	
	Gusseisen, Grauguss, Temperguss	
	Titan, Titanlegierungen	
	Hartbearbeitung	
	Kupfer	
	Thermoplaste	
●●●●	Leistungsfähigkeit eines Werkzeugs in den angegebenen Werkstoffen	
HPC	Hochleistungszerspanung (High Performance Cutting)	

Formeln

Z = Zähnezahl

d = Schneidkreis - Ø

$$n = \text{Drehzahl} \quad n = \frac{v_c \cdot 1000}{d \cdot \pi} \quad (1/\text{min})$$

$$v_c = \text{Schnittgeschwindigkeit} \quad v_c = \frac{d \cdot \pi \cdot n}{1000} \quad (\text{m}/\text{min})$$

$$f_z = \text{Vorschub / Zahn} \quad f_z = \frac{v_f}{Z \cdot n} \quad (\text{mm}/\text{U})$$

$$v_f = \text{Vorschubgeschwindigkeit} \quad v_f = f_z \cdot Z \cdot n \quad (\text{mm}/\text{min})$$

$$Q = \text{Materialabtragungsrate} \quad Q = \frac{a_e \cdot a_p \cdot v_f}{1000} \quad (\text{cm}^3/\text{min})$$

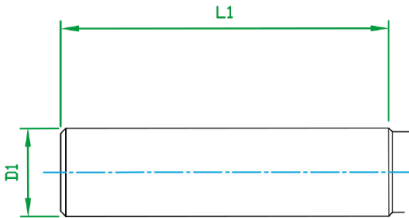
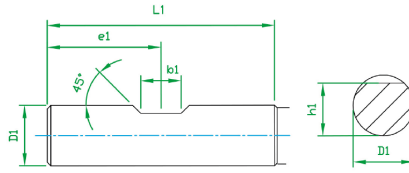
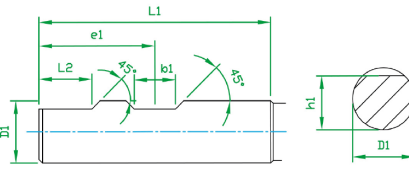
Norm	Zeichnung	Maße in mm					
		D1	b1	e1	h1	L1	L2
DIN 6535 Form HA		6				36	
		8				36	
		10				40	
		12				45	
		14				45	
		16				48	
		18				48	
		20				50	
		25				56	
		32				60	
DIN 6535 Form HB mit einer Mitnahme- fläche		6	4.2	18	5.1	36	
		8	5.5	18	6.9	36	
		10	7	20	8.5	40	
		12	8	22.5	10.4	45	
		14	8	22.5	12.7	45	
		16	10	34	14.2	48	
		18	10	24	16.2	48	
		20	11	25	18.2	50	
DIN 6535 Form HB mit zwei Mitnahme- flächen		25	12	32	23.0	56	17
		32	14	36	30.0	60	19

